



The new **BMPlus-3z Zone Control System** includes easy “System Specific” programming via the large LCD screen. The LCD also displays real time “Zone Control Information” such as the status of each zone Thermostat, System mode of operation, Supply & Outside Air Temperatures, Fresh Air function & fault status of the new Safety Interlock A2L mitigation. Connect the innovative Data terminal to our model DAPC, and modulate your EWC zone dampers to control the HVAC system static pressure. Control 24v multi-stage HVAC systems and create up to nine air zones in your home or small business. Use EWC 24v motorized dampers and any legacy 24v thermostat you desire, including WiFi models. Specify the Next Generation BMPlus-3z Zone Controller and re-discover the most intuitive and technician friendly Zone Controller in the HVAC Industry.

Nine Zone Capacity

Control 2 or 3 zones with a single BMPlus-3z. Create 6 zones by connecting a single XM-3z expansion module to the BMPlus-3z. Create 9 zones with two XM-3z expansion modules.

Compatible HVAC Systems

Control 3 Heat / 2 Cool Dual Fuel systems or conventional Heat Pumps. You can also control 24v single stage or 2 Heat / 2 Cool HVAC systems (Gas, Oil, Electric, Hydronic).

Compatible Thermostats

The BMPlus-3z is compatible with typical 24vac single stage Heat/Cool thermostats and 2 Heat/ 1Cool Heat Pump thermostats. Hard wired, Battery/Power Robbing types are also compatible. The BMPlus-3z is compatible with Smart WiFi thermostats as well, assuming a sufficient number of wires exist at each thermostat location. *See Notes on Page 19.*

Automatic Heat / Cool Changeover

The BMPlus-3z is compatible with “automatic changeover” thermostat settings, which allows individual zoned comfort for the End User.

Status LCD

System Heat ON

The Liquid Crystal Display continuously scrolls to show the status of the zoned HVAC system (Idle, Heating, Cooling). Status of Safety Interlock is displayed and the System static pressure if the DAPC is connected.

4 Button LCD Programming



Four buttons are provided just below the LCD screen. Press the Left or Right button to advance thru the BMPlus-3z Menu and observe the features applicable to your HVAC system. When you see the feature you want, press the Up or Down button (one or more times) to make your selection. Auto Save will occur.

System LED's

In addition to the LCD, a total of 8 colored LED's provide visual indication of the HVAC system status & zone damper position.

Damper LED's

Three green LED's (Zone 1 Open, Zone 2 Open and Zone 3 Open) provide instant visual indication of the zone damper positions.



Model BMPlus-3z Zone Control

Digital Damper Position Feature

The BMPlus-3z has a 2 way “Data” terminal for use with the Ultra-Zone model DAPC. The “Distributed Air Pressure Controller” monitors Open & Close zone damper commands from the BMPlus-3z data signal. The DAPC can modulate your none calling zone dampers to control the static pressure at the design or desired set-point. The DAPC will also share the system static pressure reading with the BMPlus-3z. *See page 22.*

24vac Accessory Output

The BMPlus-3z provides a 24vac output that you can use to power accessories like the DAPC modulating damper control, or the SBD2 Smart Bypass Damper.

Fresh Air Feature

Available spare Zones 3,6, and 9 may be used to control a Fresh Air damper. The BMPlus-3z will calculate “Minutes of Fresh Air” per hour for you, based on several variables. *See page 8 & 9 for details.*

Safety (S1 / S2) Interlock Feature NO or NC

The BMPlus-3z includes an on-board Safety Interlock. The S1/S2 terminals can be connected to “dry contact” wet switches, fire/smoke monitors or A2L refrigerant leak monitors. If the safety device activates, the BMPlus-3z will shut-down the HVAC system and close all zone dampers, or open all zone dampers but only run the fan. This friendly feature eliminates the question “How do I wire my safety devices” on a zoned HVAC system. *See page 6 & 17 for details.*

INSTALLATION INSTRUCTIONS

The zoned installation shall be performed by qualified persons in compliance with National and / or Local Mechanical / Building Code including applicable ANSI standards.

MOUNTING: Choose a suitable location to mount the BMPlus-3z housing. Suitable locations are on the Return Duct, a Nearby Gypsum Wall or Plywood mounted to wall studs. **Do Not** mount the BMPlus-3z on the Supply duct. **Do Not** mount the BMPlus-3z directly to the Air-Handler, Furnace, Hydronic Coil Cabinet or Evaporator Cabinet.

POWER SUPPLY: The BMPlus-3z requires a **dedicated** 24vac transformer. 40va minimum - 75va maximum. **Do Not steal 24vac power from the HVAC system!** Doing so will void the warranty. The zoned installation shall comply with National and/or Local Electrical Code.

WIRING: Use standard 18awg copper multi-conductor cable. Plenum rated where applicable. Connect the dedicated 24vac Power Supply to the BMPlus-3z, then wire-up thermostats & dampers. Use the openings provided on the housing as the wire entry-way. Stripping the cable's jacket back to the point where the cable enters the housing, reduces bulk and allows easy routing of the individual wires to the terminal blocks. Use the housing's wire tie loops to secure the wiring and achieve a professional looking installation.

PROGRAM: Scroll thru the LCD menu and select the type of HVAC system you want to control. You may select the type of thermostat you intend to use (Heat/Cool or Heat Pump) as well. The BMPlus-3z allows the use of Heat/Cool thermostats with Heat Pump systems. Accept the default supply air sensor temperature limits or you can fine tune them to your liking.

Caution! Changing menu settings without full knowledge of the feature function, may result in unsafe and/or incorrect HVAC system operation!

FINISH: Program all thermostats for the correct system type and run the system thru it's paces. Observe the HVAC system in all possible modes of operation. Check the Zone Dampers for proper operation and the Bypass Damper (if present) as well. Adjust the BMPlus-3z menu settings as needed. It's important to "manually balance" the duct work with all zone dampers open, when the system is running at 100% of the rated (CFM) airflow.

Typical Up-flow Installation with DX Cooling

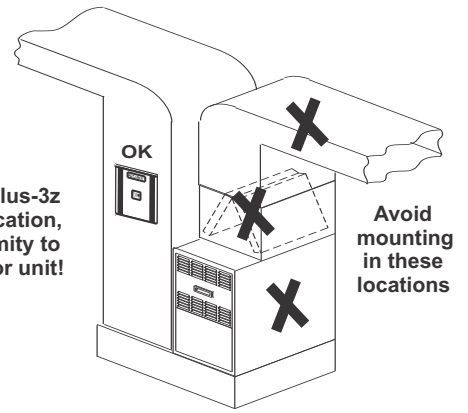

Install the BMPlus-3z in a suitable location, in close proximity to the HVAC indoor unit!

Avoid mounting in these locations

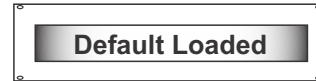
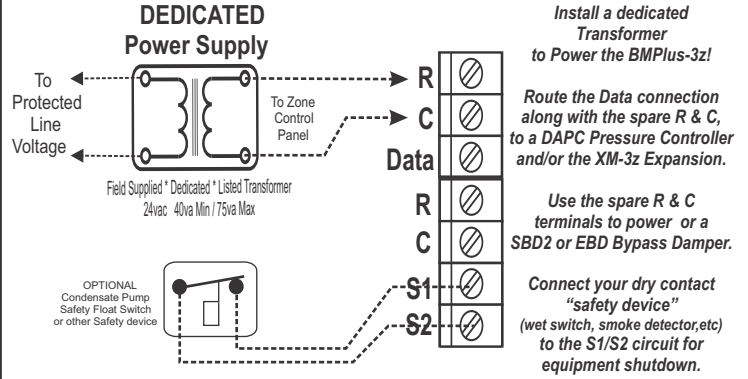

If desired, you can reset the BMPlus-3z back to factory settings!

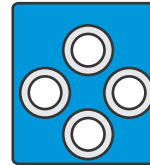

Upon Power Up, Press and Hold the Left & Right buttons to Load Factory Default Values, then Release.

BMPlus-3z code 1.36 SPECIFICATIONS and MENU ITEMS:

NUMBER OF ZONES: 2 or 3 zones. Expandable to 6 or 9 zones using 1 or 2 model XM-3z Expansion Modules. See Tech Bulletin 090375A0281 for more information.

COMPATIBLE EQUIPMENT: 24vac Gas/Oil/Electric/Hydronic systems – 1 or 2 Stage Heat & 1 or 2 Stage Cool. Or 24vac Conventional or Dual Fuel Heat Pump systems – Up to 3 Stage Heat & 2 Stage Cool.

COMPATIBLE THERMOSTATS: 24vac single stage Heat/Cool Thermostats. (WiFi is OK). Or 24vac 2 stage Heat, 1 Stage Cool Heat Pump Thermostats. (WiFi is OK).

COMPATIBLE DAMPERS: 24vac EWC® Models URD, ND, and SID 3 wire (Power Open/Power Close) type dampers.

MAX. DAMPERS PER Zone System @ 40va power supply: ND, URD, or SID Dampers @ (1.5va) per motor = 15 total with Model DAPC, EBD or SBD. **No Expansion!**

MAX. DAMPERS PER 3 zone System @ 50va power supply: ND, URD, or SID Dampers @ (1.5va) per motor = 20 total with Model DAPC, EBD or SBD. **No Expansion!**

OVER-CURRENT (Auto-Reset) PROTECTION:

F1 = 300mA OC protection for the Primary Logic Circuit.

F2 - F4 = 750mA OC protection for each Zone Circuit.

F5 = 100mA OC protection for the Data circuit.

NOTE: Solid State OC protection de-rates approx 20% at high ambient temperatures.

BMPlus-3z Current & Power: 325mA / 8va.

POWER SUPPLY: 24vac 50/60 Hz - 40va recommended. 40va Min - 75va Max.

AMBIENT OPERATING CONDITIONS:

TEMPERATURE: -4° to 158°F (-20° to 70°C).

HUMIDITY: 0% - 95% Rh Non-Condensing.

HOUSING SPECIFICATIONS: High Strength Impact Polystyrene. HB flame rating. UV resistant.

TERMINAL BLOCK SCREW TORQUE: 3.5 inch lb (0.4nM).

ACCESSORIES:

Model SAS – Supply Air Sensor (Included / Highly Recommended).

Model OAS – Outside Air Sensor (Optional / Highly Recommended).

Model DAPC – Airflow and static pressure control (Optional / Recommended).

Model SBD2 – Smart (self-balancing) Bypass Damper (Optional / Recommended).

Model CPLS – Coil Protection Lockout Switch (Freeze Stat / Optional / Recommended).

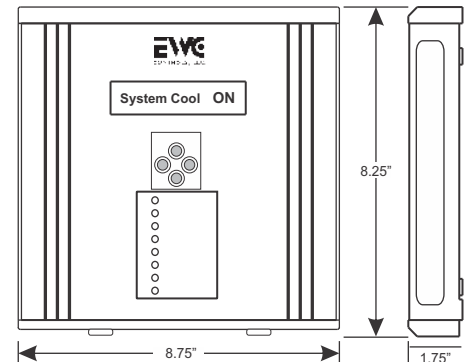

NOMINAL DIMENSIONS

9" X 9" X 2"

BMPlus-3z Menu Features, Default Settings and Selectable Range

FEATURE	DEFAULT	RANGE TO SELECT
LCD Contrast	22	15 - 30
SystemType	Heat/Cool	Heat/Cool, Heat Pump or Dual Fuel
T-Stat Type <small>note 1</small>	Heat/Cool	Heat/Cool, Heat Pump 'O' or Heat Pump 'B'
Emergency <small>note 2</small>	OFF	OFF or ON
Fan Mode <small>note 3</small>	Gas	Gas or Hydro (Electric)
Hydro Fan Dly <small>note 3</small>	N	N or Y (If Y, fan starts 45 seconds after W1)
Purge w/Fan	N	N or Y (If Y, fan runs during Purge Delay)
Purge Delay	90s	60, 90, 120, 150 or 180 seconds
S1 & S2	Purges	Purges NO & NC or Stops NO & NC (see page 7)
OA Sensor <small>note 4</small>	No	No or Yes (If Yes, connect OAS)
OA Fuel BP <small>note 5</small>	32°F	5°F to 50°F (1 degree increments)
W2 Lock-out <small>note 6</small>	50°F	5°F to 95°F (5 degree increments)
Gas Limit <small>note 7</small>	145°F	120°F to 180°F
HP Limit <small>note 8</small>	120°F	105°F to 130°F
Cool Limit	43°F	35°F to 50°F
FRESH AIR OPT <small>note 9</small>	N	N or Y (If Y, see page 8 & 9)
FA Area	1800 sq ft	500 sq ft - 5000 sq ft
FA Occupants	4	2 to 12 Occupants
FA Duct Size	6 in	4in to 8in Duct
FA Minutes / Hr	50	FA Minutes/Hour calculation varies
FA HIGH LMT	80°F	70°F to 105°F
FA LOW LMT	40°F	30°F to 50°F
Stage by	Weight	Weight / Timer 5 min - 45 min / 50% Rule
Demand Delay <small>note 10</small>	20 min	Off, 5min - 45 min
W2 Heat ON @ <small>note 11</small>	60%HC / 95%HP	60% to 100% or OFF (5% increments)
Y2 Exists?	Yes	No or Yes (If Yes, see next two items)
Y2 Heat ON @ <small>note 12 & 13</small>	70% HP only	50% - 70% (5% increments)
Y2 Cool ON @ <small>note 12 & 13</small>	70% HC & HP	50% - 70% (5% increments)
Z1 H Weight	50%	0% - 100% (1% increments)
Z1 C Weight	50%	0% - 100% (1% increments)
Z2 H Weight	30%	0% - 100% (1% increments)
Z2 C Weight	30%	0% - 100% (1% increments)
Z3 H Weight	20%	0% - 100% (1% increments)
Z3 C Weight	20%	0% - 100% (1% increments)
Demand Boost <small>note 14</small>	Off	Off, 15sec, 30sec, 60sec
Stage by	Time	5, 10, 15, 20, 25, 30, 35, 40, 45 minutes
Stage by	50% Rule	Stage time 5 - 45 (5min increments)
DMPR DFLT	Open	Dampers are Open or Close (idle mode)
Fahrenheit Scale	Fahrenheit	Fahrenheit or Celsius Scale
BMPlus-3Z	V 1.36	None (Code Version for Display Only)

- 1 - [T-Stat Type] make sure you select the correct T-Stat per your system type .
- 2 - [Emergency] feature does not appear until [Heat Pump System] or [Dual Fuel System] is selected.
- 3 - [Fan Mode] & [Hydro Fan Dly] are not available when [Heat Pump System] is selected.
- 4 - The [OA Sensor Y] feature must be enabled in order to use [OA Fuel SP], [W2 Lock-out] and [FA High / Low Limit] features.
- 5 - The [OA Fuel BP] feature does not appear until [Dual Fuel System] is selected and [OA Sensor Yes] balance point is enabled.
- 6 - The [W2 Lock-out] feature does not appear until [Heat Pump System] is selected and [OA Sensor Yes] is enabled.
- 7 - The [Gas Limit] becomes [Aux Limit] when [Heat Pump System] is selected.
- 8 - The [HP Limit] feature does not appear until [Heat Pump System] or [Dual Fuel System] is selected.
- 9 - Fresh Air menu items do not appear until [FRESH AIR OPT Y] is enabled. *If enabled, Z1 & Z2 H/C weights default to 60% & 40%.*
- 10 - Demand Delay will only display if stage by weight is selected. See page 9 fore details
- 11 - For all HP systems, a minimum 10% dead-band is enforced between [W2 Heat ON @] and the [Y2 Heat ON @] values.
- 12 - [Y2 Heat ON @ 70%] does not appear until [Heat Pump System] or [Dual Fuel System] is selected!
- 13 - [Y2 Heat ON @ 70%] & [Y2 Cool ON @ 70%] will disappear if the [Y2 Exists?] feature is disabled. [No].
- 14 - [Demand boost] for more details go to page 13 step 28

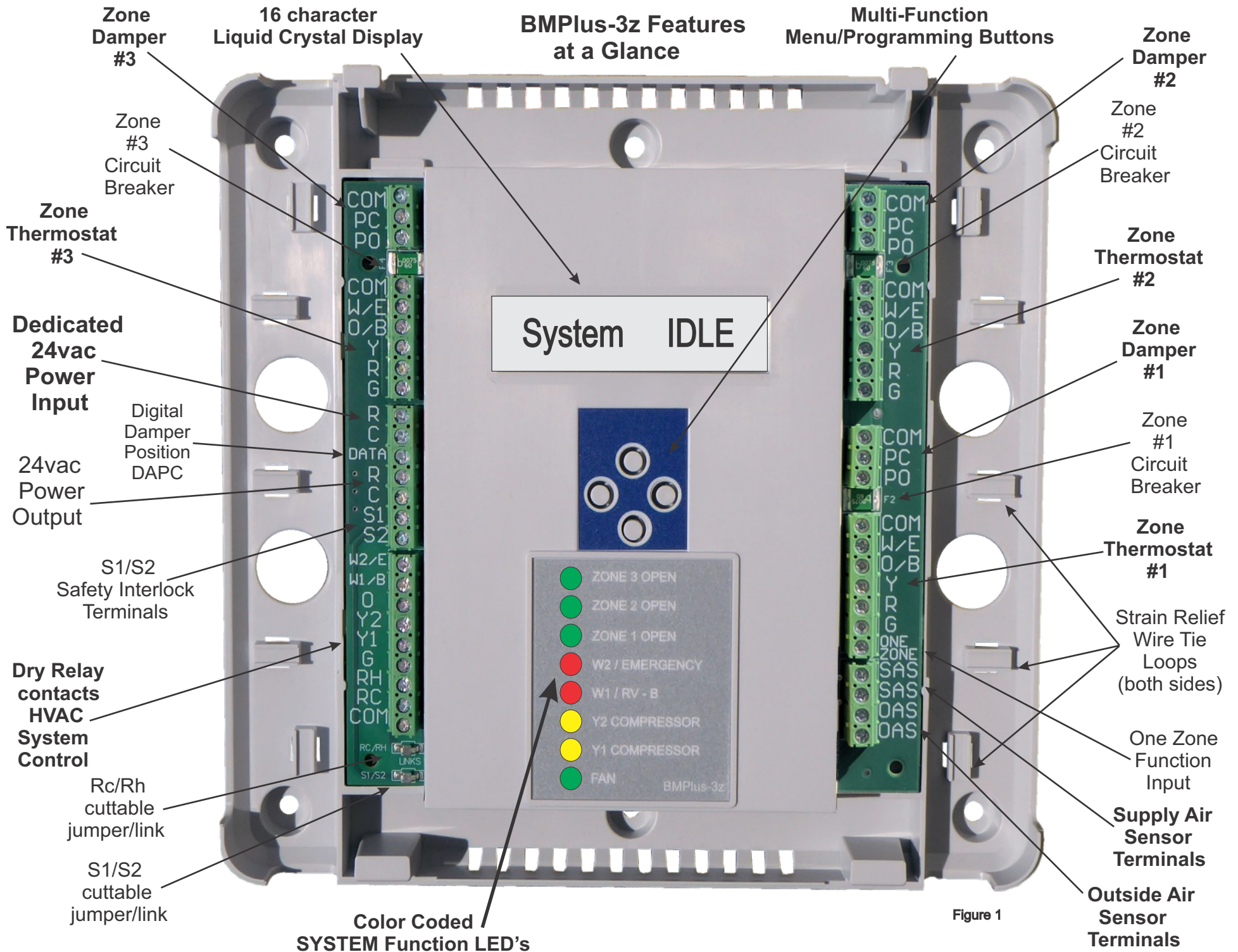
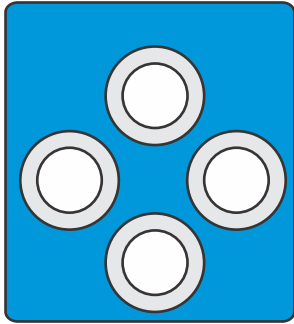

Figure 1

System Specific Programming for each type of HVAC system



Press the Left or Right button and navigate to Step 1 in the menu. Once you select your HVAC system type, the menu features that apply to that system will be displayed and are available to use as desired. Menu features that do not apply will disappear. Proceed to each step by pressing the right button and when you see the feature(s) you want to use, press the Up or Down button to make your selection.

4 Button LCD Programming

Press Left or Right to see all menu features. Press Up or Down to make your selection.

Step 1

Heat/Cool System

Or

Heat Pump System

Or

Dual Fuel System

For future reference, place a check mark in the correct box or write the selected value in the box.

Select your HVAC system type, **Heat/Cool, Heat Pump or Dual Fuel**. The BMPlus-3z will show the menu items that are applicable to your system, and hide the others.

Step 2

Heat / Cool 'Stats'

Or

HP STAT TYPE 'O'

Or

HP STAT TYPE 'B'

This feature is not displayed if Heat / Cool System was selected in Step 1.

Select the type of thermostats you want to use!

* You can select Heat/Cool thermostats for any system type, even a Heat Pump system. But you cannot mix thermostat types! All zone thermostats must be wired/programmed for either HP or H/C.

* Incorrect programming of the BMPlus-3z and/or the thermostats can result in undesirable or unsafe operation. Double check!

Step 3

EMERGENCY OFF

Or

EMERGENCY ON

This feature is not displayed if Heat / Cool System was selected in Step 1

If your Heat Pump fails and you are using standard Heat/Cool thermostats, select "ON" to enable Emergency Mode...The BMPlus-3z will bypass the Heat Pump and operate the back-up heating system, whenever the zone thermostats call for heat...This feature can be used even if "HP Stat Type O or B" was selected in Step 2.

Remember to set this feature back to "OFF", after your Heat Pump is repaired and operational.

Step 4

Y2 Exists? Yes

If you have a single stage AC or HP unit, change this setting to NO! Otherwise, leave it at YES.

Step 5

Fan Mode GAS

Or

Fan Mode HYDRO

Fan mode features step 5 & 6 are not displayed if Heat Pump System was selected in Step 1

Select how you want the Indoor Fan to operate during Heating operations. Select "GAS" if you have a Gas or Oil Furnace with A/C. Select "HYDRO" if you have an Air-Handler with a Hot Water Coil or straight Electric (resistance) Heat .

Step 6

Hydro Fan Dly Y

If you selected "HYDRO" in step 5, then select Y for YES, to delay the indoor fan when a heating operation starts. Waiting 45 seconds to start the fan allows the Hydro coil a chance to heat up before the air starts moving.

Step 7

Purge w/Fan N

The BMPlus-3z can force the Indoor Fan to run (during the Purge Delay) at the end of heat and cool demands.

The Purge Delay is described below in Step 8.

If you don't need this feature, select N for NO, which is the factory default setting. Select Y for YES, if you want the Indoor Fan to run during the Purge Delay.

Hydronic (Hot Water) systems will benefit from this feature because the Hydronic coil is holding a lot of residual heat after the water stops flowing.

If set to YES, the BMPlus-3z will force the indoor fan to run during the Purge Delay. If set to NO, the Purge Delay will still occur, but the BMPlus-3z will not force the fan to run during the Purge Delay.

Purge Cycle Functions and Safety Interlocks

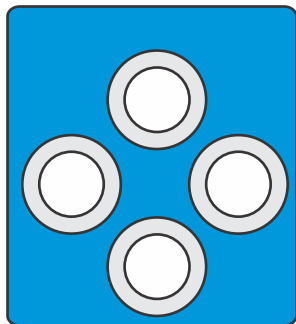

Press the Left or Right button to advance thru the BMPlus-3z Menu and observe all of the features. When you see the feature you want to change, press the Up or Down button (**one or more times**) to make your selection, Your changes are auto-saved. Select only the functions you want or need. *For future reference, place a check mark in the correct box below or write the selected value in the box.*

4 Button LCD Programming

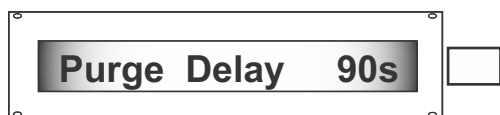

Step 8

The "Purge Delay" occurs at the end of every Heating or Cooling operation. The Purge Delay cannot be disabled, but you can select how long the delay occurs. Purge Delay is adjustable from 60, 90, 120, 150 or 180 seconds. The factory default is 90 seconds.

When the last zone is satisfied, the BMPlus-3z will hold that zone's damper in the Open position (*all others remain closed*) so the remaining hot or cold air, flows into the last zone that needed it and not the others. NOTE: The Purge delay times out concurrently with the fixed 4 minute Short Cycle delay. ie, A purge delay of 60seconds results in a 3 minute short cycle delay. A purge delay of 90seconds, results in a 2.5 minute short cycle delay. A purge delay of 180seconds results in a 1 minute short cycle delay.

After the Purge Delay expires, the BMPlus-3z will open all dampers and enter "short cycle delay" or "change-over delay", if active zone demands are detected. If no other zone demands are detected, the BMPlus-3z will enter "idle mode" and wait until demands are detected.

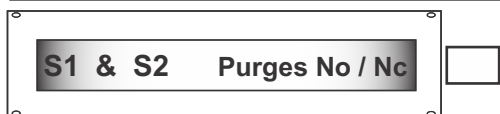

Step 9

OR



Default = Purges NC for A2L refrigerant applications!

S1 / S2 Safety Terminals

Compatible with N.O. or N.C. Contacts

The S1/S2 safety terminals can be used with either **Normally Open (N.O.)** Or **Normally Closed (N.C.)** Dry contact safety device. Including float switches, condensate overflow switches, pressure switches, and A2L refrigerant leak detector systems.

By default, the control assumes **N.C. Contacts** (closed during normal operation). If using **N.O. Contacts**, simply change the **S1/S2 mode setting** in the system configuration menu.

This added flexibility allows seamless integration of a wider range of field-installed safety devices without requiring additional relays or complex rewiring.

Purge Mode (Default)

* Forces all connected zone dampers to FULL OPEN position and runs the indoor fan ONLY.

* Heating and cooling calls are ignored until the S1/S2 safety contacts reset.

Recommended For:

- * A2L Refrigerant Leak Detector systems
- * Emergency Pan Overflow Switches
- * Condensate Pump Safety Switches
- * Condensate Trap Overflow Switches

Purpose:

To ventilate the structure by moving air through the ductwork during a safety event while bypassing heating or cooling operation.

Stop Mode

* Forces all connected zone dampers to FULL CLOSED position and stops the indoor fan.

Recommended For:

- * Smoke Detectors
- * Fire Alarm Panels

Purpose:

To help minimize smoke migration via the ductwork by halting air movement and closing all dampers.

Important:

To monitor any safety device, the **S1/S2 factory-installed link / jumper must be cut.**

Do not apply voltage to the S1 or S2 terminals. These inputs are for **dry contact devices only.**

S1 / S2 Mode setting must be configured correctly in the installer menu based on the type of safety device used.

Residential zone dampers are NOT fire/smoke rated.

Warning: No claims, specifications, or guarantees of fire/smoke performance are made or implied by the use of Stop Mode.

LCD Screen Notification:

If an interlocked safety device activates, the BMPlus-3z LCD screen will notify you by displaying S1/S2 Lockout!

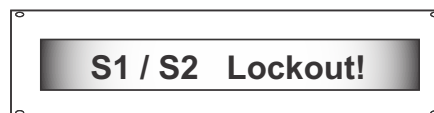

When the safety device contacts re-close, the "lockout" screen shown above will go away, and the BMPlus-3z will resume HVAC operations after a 4 minute delay expires.

See page 16 for details on connecting safety devices!

Supply Air Temperature Safety Limits & Function

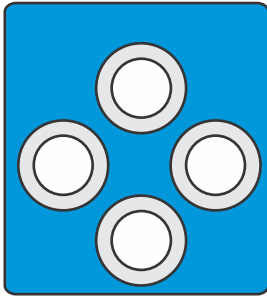

Press the Left or Right button to advance thru the BMPlus-3z Menu and observe all of the features. When you see the feature you want to change, press the Up or Down button (**one or more times**) to make your selection, Your changes are auto-saved. Select only the functions you want or need. *For future reference, place a check mark in the correct box below or write the selected value in the box.*

4 Button LCD Programming

Step 14

HP Limit
120°F

The default value of 120°F, is good for most Heat Pumps running R410A refrigerant. For Heating operations, set this temperature to a corresponding condensing pressure, that will avoid tripping the high head pressure safety device in your Heat Pump.

You may want to reference a Temp/Pressure chart and select a different value and/or a different refrigerant type. The adjustable Heat Pump Limit range is 105°F to 130°F.

If the supply air temperature exceeds the selected "HP Limit" value, the BMPlus-3z will cycle the HP off-line for 4 minutes to avoid tripping the high head pressure device on your HP. After 4 minutes expires the BMPlus-3z will resume normal HP heating operations.

NOTE: The last zone calling will be forced open, during the 4 minute period, in order to rapidly dissipate heat. The dampers will go back to their intended positions after 4 minutes expires and the supply air temperature drops.

NOTE: Excessive short cycling on the HP Limit, may indicate a dirty air filter, a faulty zone damper, unbalanced bypass duct and/or under-sized duct-work, or refrigerant over-charge

Step 15

Cool Limit
43°F

The default Cool Limit set-point is 43°F, to avoid a coil freeze-up. Although you may need to set this value slightly lower to accommodate "Dehumidify" operations. We do not recommend a **Cool Limit lower than 38°F.**

If the actual supply air temperature exceeds the selected "Cool Limit" value, the BMPlus-3z will cycle the condensing unit off-line for 4 minutes. When 4 minutes expires and the supply air temperature rises above the limit value, the BMPlus-3z will resume normal cooling operations.

NOTE: The last zone calling will be forced open, during the 4 minute period, in order to rapidly warm up the coil. The dampers will go back to their intended positions after 4 minutes expires and the supply air temperature rises above the Cool Limit set-point.

NOTE: Excessive short cycling on the Cool Limit, may indicate a dirty air filter, a faulty (closed) zone damper, unbalanced bypass duct and/or under-sized duct-work, or a low refrigerant charge.

NOTE: Resist the urge to keep lowering the Cool Limit set-point, in order to avoid short cycling! Look for the root cause of "Why is the supply air too cold?" and fix it! Continued lowering of the Cool Limit set-point is not recommended.

OA Sensor
Yes

Step 10

*Do I need this
Outdoor Air
Function?*

Select "Yes" for OA Sensor if you want to set an OA "Balance Point" for a dual fuel HP or "lock-out" electric strip heat above mild OA temperatures **and/or** "lock-out" Fresh Air functions during extreme outdoor temperatures. **See Fresh Air on pages 8, 9.**

OA Fuel BP
32°F

Step 11

*This menu feature is
displayed for
Dual Fuel HP systems!*

Navigate to the [OA Fuel BP] feature and select your Outdoor Air Fuel Balance Point. The BMPlus-3z will default to 32°F, or select your own Balance Point from a range of 5°F to 50°F.

W2 Lock-out
50°F

Step 12

*This menu feature is
displayed for conventional
Heat Pump systems!*

The [W2 Lock-out] feature prevents electric "auxiliary" heat operation above the selected outdoor temperature. ie, at 50°F (or lower) auxiliary heat is allowed to operate at (5°F - 95°F).

Gas Limit
145°F

Step 13

Aux Limit
145°F

The default value of 145°F, is good for most furnaces and the adjustable Gas Limit range is 120°F to 180°F.

Set this value 5 - 10 degrees below the factory high temperature safety limit on your Gas, LP or Oil furnace.

If the actual supply air temperature exceeds the selected "Gas Limit" value, the BMPlus-3z will cycle the furnace off-line for 4 minutes to avoid a lock-out condition on your furnace. After 4 minutes expires and the supply air temperature drops below the limit value, the BMPlus-3z will resume normal heating operations.

NOTE 1: Last zone calling will be forced open, during the 4 minute period, in order to rapidly dissipate heat. The dampers will go back to their intended positions after 4 minutes expires and the duct temperature drops.

NOTE 2: Excessive short cycling on the Gas Limit, may indicate a dirty air filter, a faulty zone damper, unbalanced bypass duct and/or under-sized duct-work.

NOTE 3: On Heat Pump (non-dual fuel) applications, the "Gas Limit" set-point changes to "Aux Limit" set-point.

Note 3 assumes the Supply Air Sensor is installed in the Supply Plenum (after the strip heat) rather than "inside" the Air Handler's blower section (before the strip heat). If the sensor is installed "inside" the Air Handler, set the "Aux Limit" down to 120°F, to match the HP Limit.

Fresh Air Option / Solution (FA)

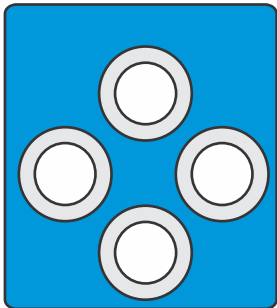

Zone 3, may be used as a fresh air solution on 2 zone applications! Follow the steps below to achieve a mechanical fresh air solution for your healthy home. **Note:** The fresh air function will operate without regard to the outside temperature, unless you install an outside air sensor and connect it to the BMPlus-3z. **Note:** You may adjust the “minutes/hour” of fresh air to your liking, if you don’t agree with the fresh air calculation made by the BMPlus-3z.

FA Square Footage, FA Occupants, and FA Duct size are not displayed until Fresh Air Option is enabled!



Step 16

On two zone applications, the spare Zone #3 may be used to control a Fresh Air damper. The BMPlus-3z will calculate “Minutes of Fresh Air per Hour” for you, based on the variables you set, as described on this page. Zone 6 or 9 maybe used when needed.

Select N for NO, if you do not want or need this feature.

Select Y for YES to activate this feature and use Zone 3 to operate a Fresh Air (FA) damper.

NOTE: You must install a dedicated Outside Air damper (24vac motorized) and route the OA duct to the return air plenum of the HVAC system. Make sure the Outside Air “passes through” the HVAC system’s primary air filter or provide a dedicated Outside Air filter.

NOTE: DO NOT locate the OA intake within 3 ft of any appliance vent/exhaust or sewer vent pipe. Provide an insect/rodent/bird screen on the outside air duct intake. **Follow local and/or national mechanical code.**

NOTE: The “Minutes of Fresh Air/Hour” calculated by the BMPlus-3z, does not credit for “other means” of Fresh Air coming into the building such as an ERV/HRV, open windows/doors or natural infiltration. You may reduce the “Minutes of FA/Hr” to your liking, if

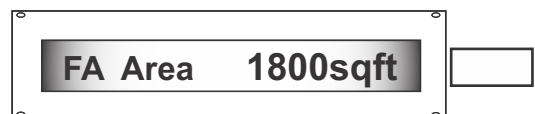

Step 17

If you selected Y for Yes on Step 16, this screen will appear next in the menu.

Set the Square Footage of the home on this screen by pressing the up or down buttons! Each press of the button adjusts the square footage 100sqft at a time.

The adjustable range is 500sq ft to 5000 sq ft and the default is 1800sq ft.

You may round up or down to get as close to the actual square footage as you can.

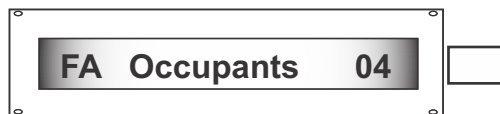

Step 18

This screen will appear after step 17.

Set the total number of people living in (occupying) the home on this screen. The default number of occupants is 4 people. The adjustable range is 2 to 12 people.

NOTE: Do not include persons who are staying in the home for a short time period. ie weekend visitors.

NOTE: Pets are optional and may be included if desired.



Step 19

This screen will appear after step 18.

Select the size (diameter) of your Outside Air duct. Most residential/light commercial OA duct is round “steel” duct.

The default diameter is 6” (6in). The adjustable range is from 4” diameter up to 8” diameter.

NOTE: If your OA duct is rectangular, use a duct calculator to determine the equivalent diameter and select that size. ie 9” x 6” duct = 8” diameter round duct.

NOTE: Larger diameter OA duct will result in fewer FA minutes/hour, because the larger duct can move more air than smaller diameter duct.

Once you have selected the parameters for Fresh Air cycling, the BMPlus-3z will calculate the “Minutes of Fresh Air/Hour” required, in order to properly ventilate your home with outside air. *Example below is 35 minutes per hour.*



NOTE: The BMPlus-3z will always attempt to achieve the required minutes of FA/Hr by opening the OA damper during heating and cooling operations. This will reduce the impact of introducing cold or hot air into the home.

If the BMPlus-3z does not detect a sufficient quantity of heat or cool demands (in a given hour) in which to open the FA damper, the BMPlus-3z will force a FA cycle (at the end of the hour), to satisfy the number of FA minutes remaining in that hour.

Fresh Air / Staging

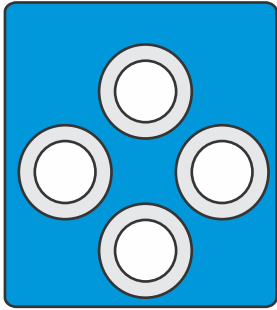

The BMPlus-3z offers three staging methods Stage by Weight (default), Time-Based and 50% Rule Staging with Stage by Weight recommended for its superior flexibility and precision, allowing separate weight settings for heating and cooling for optimal system performance.

4 Button LCD Programming

Step 20



And



This feature is not displayed until OA Sensor is enabled in Step 6

* The FA High Limit adjustment range is 70°F to 105°F.

* The FA Low Limit adjustment range is 30°F to 50°F.

The FA High & Low limit screens will not display in the menu until [OA Sensor] is enabled. Install an outside air sensor and connect it to the BMPlus-3z. Otherwise, Fresh Air functions will operate without regard to outdoor temperature.

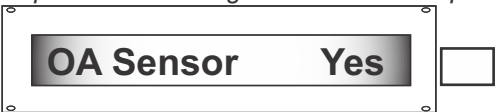

If you have enabled the Fresh Air Option in Step 16, you may stop Fresh Air function at extreme outdoor temperatures if you install and connect an outside air sensor (P# OAS) to the BMPlus-3z.

Step 21

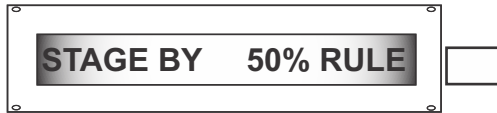
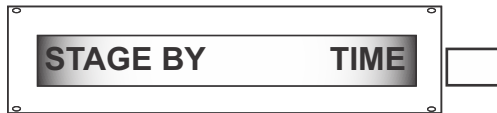
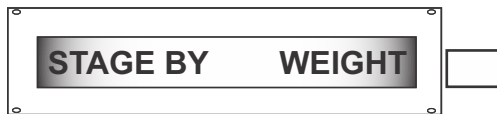

STAGING CONTROL OPTIONS

The BMPlus-3z zone control system offers three distinct staging methods to suit a variety of system needs and installer preferences. **Stage by Weight** is the default staging method and is recommended for its advanced capabilities and flexibility. It allows the installer to assign different weight values for each zone, independently for heating and cooling, offering precise control over when the system stages up or down. This method also enables access to the **Demand Delay** feature, which provides additional staging control by allowing the first stage to operate independently before higher stages are considered.

In addition to Stage by Weight, the BMPlus-3z can also limit staging utilizing Stage By Time, which activates additional stages only after a set amount of elapsed time. The 50% Rule, a simplified method that limits staging based on the percentage of active zones is only available when Time-Based Staging is selected. The 50% rule will limit the staging-up process if less than 50% of the active zones are calling. The BMPlus-3z will continue to use the first stage to satisfy the demand. Installers can configure the preferred method through the system's setup menu, allowing flexibility to match the needs of each application.

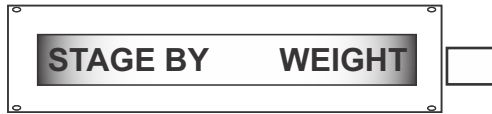

REMEMBER Stage by Weight is the BMPlus-3z's default and most advanced staging method, offering precise control by staging equipment according to the percentage of active zones. It provides the flexibility to set different weights for heating and cooling, making it ideal for achieving optimal comfort and efficiency under varying demand conditions.

Step 22



Demand Delay Factory setting will be set for 20 minute

The Demand Delay feature allows the first stage (Y1 or W1) to operate independently for a set amount of time before staging up to higher levels (Y2 or W2). This improves efficiency by giving the first stage a chance to satisfy the demand without engaging additional capacity too quickly.

While Demand Delay is active, total system demand is capped at **50%**. If Demand Boost is enabled, any active zone or combination of zones below 50% will be allowed to boost up to the 50% cap. Once the Demand Delay timer expires, the cap is lifted and Demand Boost can increase the system demand above **50%** as needed, allowing staging to the next level.

Adjustable from 5 to 45 minutes, in **5-minute increments**, or select **OFF** to disable Demand Delay and allow staging to follow zone demand weighting without restrictions.

W2 and Y2 Heat/Cool Staging Logic

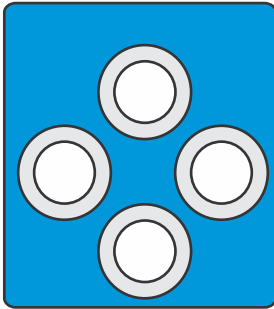

Full (multi-stage) BTU capacity should not be required until all (or most) of your zones are calling for Heat or Cool at the same time. So, if a single small zone (low Heat loss/gain) calls alone, it's weight assignment can be very low (5 - 45%) so that zone cannot receive 2nd stage heat or cool capacity. When 2, 3 or all zones call together, their combined weight should be sufficient to match/exceed the set-point required to energize Y2 Cool, Y2 Heat and/or W2 Heat.

4 Button LCD Programming



Step 23

If you selected a Heat/Cool system in Step 1, the default value is 60% "system demand" to control W2 in your furnace.

Zone Demand (weight) = System Demand (output).

W2 (Gas High Fire) will energize when the heating "WEIGHT" of one or more zone thermostats, matches or exceeds 60%.



If you selected a HP or Dual Fuel system in Step 1, the default value is 95% "system demand" to control W2 in your HP.

W2 (Auxiliary Heat) will energize when the heating "WEIGHT" of one or more zone thermostats, matches or exceeds 95%.

[W2 Heat ON] is adjustable from 65% to 100% in 5% increments or you can disable this feature by selecting OFF.

Zone Demand (weight) = System Demand (output).

See Step 24, Examples 3, 4, and 5...

[Y2 Cool ON] only displays for two stage Cooling systems.

[Y2 Heat ON] & [Y2 Cool ON] display for two stage HP systems. These set-points are adjustable from 55% to 75%, at 5% increments.



And



Step 24

Zone Demand (weight) = System Demand (output)

Y2 Heat will energize when the heating "WEIGHT" of one or more zone thermostats, matches or exceeds 70%. TOTAL ZONE WEIGHT BECOMES THE "SYSTEM DEMAND".

Y2 Cool will energize when the cooling "WEIGHT" of one or more zone thermostats, matches or exceeds 70%. TOTAL ZONE WEIGHT BECOMES THE "SYSTEM DEMAND".

The BMPlus-3z staging logic is simple and easy to understand:

* Each zone is assigned a weight (percentage) value.

* Y2 Heat ON & Y2 Cool ON are assigned a percentage set-point.

* Total weight from one or more thermostats must equal or exceed the Y2 Heat or Cool "ON" set-point, in order to stage-up.

Example 1: Two stage Cooling

Z1 C weight = 70%

Z2 C weight = 30%

Y2 Cool ON @ 70%

Zone 1 can receive Y2 Cooling but Zone 2 cannot, unless it calls along with Z1.

Example 2: Two stage Cooling

Z1 C weight = 40%

Z2 C weight = 60%

Y2 Cool ON @ 60%

Zone 2 can receive Y2 Cooling but Zone 1 cannot, unless it calls along with Z2.

Example 3: Two stage (gas) Heating

Z1 H weight = 50%

Z2 H weight = 50%

W2 Heat ON @ 65%

Both zones must call together, in order to stage-up to W2 gas Heat.

Example 4: Two stage (HP) Heating (Y2 does not exist)

Z1 H weight = 50%

Z2 H weight = 50%

W2 Heat ON @ 95%

Both zones must call together, in order to receive W2 (aux) heat.

Example 5: Three stage (HP) Heating (Y2 exists)

Z1 H weight = 34%

Z2 H weight = 33%

Z3 H weight = 33%

Y2 Heat ON @ 60%

W2 Heat ON @ 95%

Zone Weight Assignment and Staging Logic

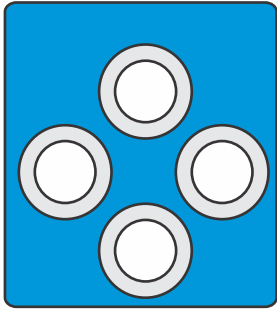

Full (multi-stage) BTU capacity should not be required until all (or most) of your zones are calling for Heat or Cool at the same time. So, if a single small zone (low Heat loss/gain) calls alone, it's weight assignment can be very low (5 - 45%) so that zone cannot receive 2nd stage heat or cool capacity. When 2, 3 or all zones call together, their combined weight should be sufficient to match or exceed the percentage required to energize Y2 Cool, Y2 Heat and/or W2 Heat.

4 Button LCD Programming

Step 25

Z1 H WEIGHT 50%

And

Z1 C WEIGHT 50%

Accept the default "Zone 1" Heat & Cool weight settings or adjust them as needed.

NOTE: Zone 1 is usually the first floor of a two story dwelling, with considerable heat loss and square footage. **As such, Zone 1 may need more Heat weight than Cool weight.**

Example 1:

Z1 H weight = 60%

Z1 C weight = 40%

Example 2:

Z1 H weight = 70%

Z1 C weight = 30%

In Example 1 & 2, Zone 1 Heat weight is greater than Cool weight.

So depending on the Y2 Heat ON or W2 Heat ON set-point, Zone 1 can receive more Heating capacity than Cooling capacity, when calling alone (without other zones).

Step 26

Z2 H WEIGHT 30%

And

Z2 C WEIGHT 30%

Accept the default "Zone 2" Heat & Cool weight settings or adjust them as needed.

NOTE: Zone 2 is usually the 2nd floor of a two story dwelling with considerable heat gain and square footage. **As such, Zone 2 may need more Cool weight than Heat weight.**

Example 3:

Z2 H weight = 40%

Z2 C weight = 60%

Example 4:

Z2 H weight = 25%

Z2 C weight = 75%

In Example 3 & 4, Zone 2 Cool weight is greater than Heat weight.

So depending on the Y2 Cool ON set-point, Zone 2 can receive more Cooling capacity than Heating capacity, when calling alone (without other zones).

Step 27

Z3 H WEIGHT 20%

And

Z3 C WEIGHT 20%

Accept the default "Zone 3" Heat & Cool weight settings or adjust them as needed.

NOTE: Zone 3 is usually the Basement of a 2 or 3 story dwelling with moderate heat loss and minimal heat gain. **As such, Zone 3 may need some Heat weight and little to no Cool weight.**

Example 5:

Z3 H weight = 15%

Z3 C weight = 05%

Example 6:

Z3 H weight = 20%

Z3 C weight = 00%

In Example 5 & 6, Zone 3 may not need all of it's 20% default Cool weight. So you can give some to another zone.

Any zone with a 5% Cool/Heat weight assignment, can still receive 1st stage Cooling or Heating capacity.

Any zone with 00% will not show heat or cool capacity

Check out the "weight assignment" examples below! Your weight assignments may differ depending on numerous factors in your zoned home.

Notice the sum of all H&C weight can equal 100%, but it does not have to equal 100%. You may not need to use all available H&C weight for a particular zone. ie, If Zone 2 needs more Cool weight, you can deduct some Cool weight from another zone.

$$\boxed{\text{Z1 H WEIGHT 60\%}} + \boxed{\text{Z2 H WEIGHT 30\%}} + \boxed{\text{Z3 H WEIGHT 10\%}} = 100\%$$

$$\boxed{\text{Z1 C WEIGHT 05\%}} + \boxed{\text{Z2 C WEIGHT 70\%}} + \boxed{\text{Z3 C WEIGHT 05\%}} = 80\%$$

$$\boxed{\text{Z1 H WEIGHT 70\%}} + \boxed{\text{Z2 H WEIGHT 30\%}} = 100\%$$

$$\boxed{\text{Z1 C WEIGHT 30\%}} + \boxed{\text{Z2 C WEIGHT 70\%}} = 100\%$$

$$\boxed{\text{Z1 H WEIGHT 55\%}} + \boxed{\text{Z2 H WEIGHT 40\%}} + \boxed{\text{Z3 H WEIGHT 05\%}} = 100\%$$

$$\boxed{\text{Z1 C WEIGHT 40\%}} + \boxed{\text{Z2 C WEIGHT 55\%}} + \boxed{\text{Z3 C WEIGHT 00\%}} = 95\%$$

$$\boxed{\text{Z1 H WEIGHT 90\%}} + \boxed{\text{Z2 H WEIGHT 10\%}} = 100\%$$

$$\boxed{\text{Z1 C WEIGHT 40\%}} + \boxed{\text{Z2 C WEIGHT 60\%}} = 100\%$$

Heat Pump Thermostat Auxiliary Heat Staging Logic

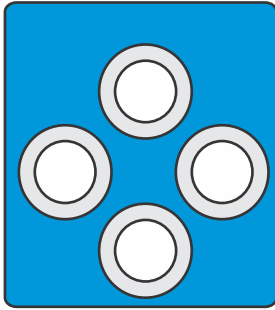

Similar to older Ultra-Zone products, The BMPlus-3z honors Auxiliary heat demands from HP style thermostats! You can always use H/C thermostats on a HP system and let the BMPlus-3z stage the heating system for you. But if you use HP thermostats instead, the auxiliary heat demand coming from any zone will double the assigned weight of that zone! This proportionally increases the System Demand, which means that zone might achieve Y2 heat or W2 heat.

4 Button LCD Programming

Z2 H WEIGHT 35%

When using **HP style Thermostats**, the assigned weight value of any zone is immediately “doubled” **if** that zone demands Auxiliary heat!

Remember... “**Zone Demand**” = “**System Demand**”

Example 1: Zone 2 is assigned 35% weight. So, when Zone 2 calls for 1st stage heat, the “System Demand” will be 35%.

System Heat 35%

If Zone 2 demands Auxiliary Heat (in addition to 1st stage) the “System Demand” will immediately increase to 70%...

If Zone 2 is the only zone demanding heat and it stops demanding Auxiliary Heat (*but still calling for 1st Stage Heat*) the “System Demand” will immediately decrease to 35%.

System Heat 70%

70% System Demand is sufficient to achieve Y2 Heat ON (*default setting*). So, even though the Zone 2 Thermostat demanded Auxiliary heat, doubling the assigned weight of Zone 2 was insufficient to match the W2 Heat ON default setting of 95%. So Zone 2 received Y2 heat instead...

If Y2 does not exist on this Heat Pump system, the W2 Heat ON setting of 95% can be lowered to 70% (*or even lower*). That would allow Zone 2 to achieve W2 Auxiliary Heat, **if** Zone 2 called for 1st stage & Auxiliary Heat at the same time.

If the Zone 2 duct-work cannot handle Auxiliary Heat airflow when calling alone, it may best to leave the W2 Heat ON setting at 95% and stage up based on “how many zones are calling for heat”. ie, If Zone 2 is demanding Auxiliary Heat and another zone (*weighted at 25%*) demands 1st stage Heat, the “System Demand” will immediately increase to 95% and the BMPlus-3z will energize W2 Auxiliary Heat.

Remember, that **any** weighted zone calling for 1st stage Heat, can achieve Y2 Heat ON and/or W2 Heat ON **if** you enable Demand Boost. **See page 13.**

Z1 H WEIGHT 28%

Z2 H WEIGHT 28%

Z3 H WEIGHT 28%

Your weight assignments may differ depending on numerous factors in your zoned home!

Remember, any zone with at least a 1% Heat Weight assignment, can receive 1st stage Heating capacity.

Example 2: All 3 zones are assigned 28% Weight for Heating demands. **Remember, the sum of your weight assignments do not have to equal 100%!**

If zone 1 calls for 1st stage heat, the “System Demand” will be 28%. **If** zone 3 also calls for 1st stage heat, the “System Demand” will increase to 55% heat. Now, **if** zone 2 calls for 1st stage heat (*all 3 zones are calling*) the “System Demand” will increase to 84% heat and Y2 Heat (@70% setting) will energize!

If only two zones are calling for heat, but one of them is also demanding Auxiliary Heat, the “System Demand” will increase to 84% heat and Y2 Heat (@70% setting) will energize!

If you prefer, lower the Y2 Heat ON setting to 55%! Then it only takes two zones calling for 1st stage heat, to achieve Y2 Heat...

If we continue the scenario above...Imagine all 3 zones are calling for 1st stage heat, and one of the zones is demanding Auxiliary Heat, the “System Demand” will increase to 100% heat, then W2 Heat (@95% default setting) will also energize!

Example 3: Both zones are assigned 40% Weight for Heating demands. Y2 does not exist and W2 Heat ON default is 95%.

Z1 H WEIGHT 40%

Z2 H WEIGHT 40%

Remember, the sum of your weight assignments do not have to equal 100%!

Your weight assignments may differ depending on numerous factors in your zoned home.

If zone 1 (*or zone 2*) calls alone for 1st stage heat, the “System Demand” will be 40%. If both zones call together for single stage heat, the “System Demand” will increase to 80% heat, which is not enough to energize W2 Heat ON @ 95%.

If only one of these two zones also calls for Auxiliary heat (in addition to HP heat) the “System Demand” will then increase to 100% heat and W2 Heat ON (@95% setting) will energize!

If that same zone stops calling for Auxiliary heat (both zones calling for HP heat only) the “System Demand” will decrease back to 80% heat and W2 Heat (@95% setting) will de-energize!

Demand Boost and Staging

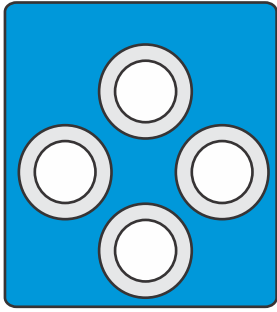

Full (multi-stage) BTU capacity should not be required until all (or most) of your zones are calling for Heat or Cool at the same time. So, if a single small zone (low Heat loss/gain) calls alone, it's weight assignment can be very low (5 - 45%) so that zone cannot receive 2nd stage heat or cool capacity. When 2, 3 or all zones call together, their combined weight should be sufficient to match/exceed the set-point required to energize Y2 Cool, Y2 Heat and/or W2 Heat.

4 Button LCD Programming

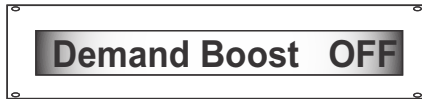

Step 28

Default value is OFF

Demand Boost (*if needed*) will add (up to 25%) percentage points to the "system Demand" output during any Heating or Cooling operation.

These "added" percentage points can "Boost" the system demand output which will allow zones with a low weight value to achieve second stage, IF the zone(s) call for a long enough period of time.

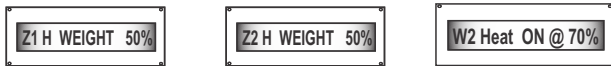

In the two zone (2 stage gas heat) example above, the Heat weight assignments for both zones is 50% and the [W2 Heat ON] set-point has been adjusted to 70%.

This means that a single zone calling alone cannot receive 2nd stage heating capacity. Both zones must call together in order to receive W2, unless you enable Demand Boost, adding 1 point every 15, 30 or 60 seconds (up to 25 points).

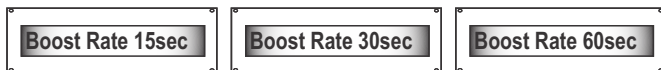

Example: If Zone 1 (50%) calls for heat and Demand Boost is adding points, then suddenly Zone 2 (50%) also calls for heat, the added weight (50% x2) trumps Boost Mode and the "System Demand" jumps to 100%, which is more than sufficient to energize W2 Heat...If one of these two zones then satisfies, the "System Demand" will immediately drop back down to 50% and W2 Heat will de-energize. Boost Mode will reset and start adding points all over again. *Delay examples are shown below.*

70 - 50 = 20 points needed for W2 or Y2. (Boost @ 15sec)

20 points / 4 points/minute = 5 minutes to W2 or Y2.

70 - 50 = 20 points needed for W2 or Y2. (Boost @ 30sec)

20 points / 2 points/minute = 10 minutes to W2 or Y2.

Step 29



Stage by Time triggers staging based on a fixed time interval. In the BMPlus 3Z, you can set this interval anywhere from 5 to 45 minutes in 5-minute increments. This method provides a consistent and predictable staging sequence, making it suitable for applications where steady timing is preferred over demand-driven operation.

Step 30

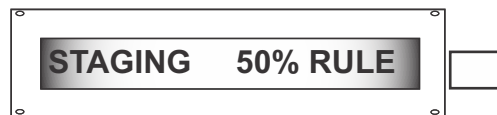

The **50% Rule** is a built-in smart staging algorithm that optimizes comfort and efficiency in multi-stage HVAC systems by managing equipment stages based on the **percentage of active zones**. This feature ensures smooth staging up through Y1, Y2, and W2 outputs, and promptly stages down when demand decreases.

Staging Up (Y1 / Y2 / W2) HP/Aux heat

- * The Bmplus3-z monitors how many zones are actively calling for HVAC operation.
- * Select the timer (5 to 45 min / 5min increments) that controls the staging delay between outputs.
- * Once **50% or more of the total zones** are active, the system begins to **stage up sequentially**:

- * **Stage 1 (Y1)** is energized first.
- * If applicable, **Stage 2 (Y2)** is energized after the time delay.
- * **Stage 3 (W2)** will energize after the delay as long as:

- * The demand is still 50% or higher.
- * If an **Outdoor Air Sensor (OAS)** is installed (**recommended**), ensure the **W2 Lock-out** is set correctly to **lock out W2 above the selected outdoor temperature**.

Staging Down

- * When **active zone demand drops below 50%**, the system will stage down immediately:
 - * All higher stages (W2 and Y2) are turned off.
 - * The system returns to Stage 1 (Y1) only. (For more staging options, use **Stage by Weight** instead of the 50% Rule.)
 - * The Staging delay timers are reset.
 - * In a **Dual Fuel (DF)** configuration, once **W2 (backup heat)** is energized, the system **locks out the heat pump** and completes the call using the **auxiliary heat source** (typically gas or oil). This is expected behavior for DF systems **no downstaging back to the heat pump** once W2 is active.

Restarting the Cycle

If demand rises back to **50% or more**, the system restarts the timer and begins the **staging up sequence** again.

Percentage Threshold Examples

Controller Model	Total Zones	Zones Required to Trigger 50% Rule
BMPlus-3z	3	2 Zones or more
BMPlus-6z	6	3 Zones or more
BMPlus-9z	9	5 Zones or more

Damper Default Position

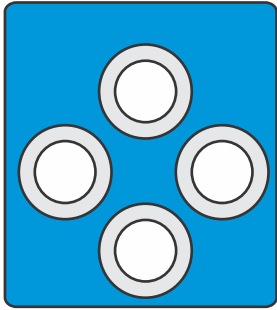

The recommended damper default position will always be in the (Open) position. But in some applications you may want the damper to be in the (Close) position with the BMPlus-3z you can set the board up for all dampers to be open or closed when the BMPlus-3z is satisfied.

4 Button LCD Programming

Done

BMPlus-3z V1.36

Step 31

DMPR DFLT Open

Select the desired damper position when the BMPlus-3z is in "idle" mode. When the BMPlus-3z does not detect any zone demands for heating, cooling or fan operations, you can force ALL zone dampers Open or Closed.

The default (**recommended**) damper position is Open, but there may be some applications where it's more energy efficient to default zone dampers to the Close position.

If your Furnace or Air Handler is located in the attic along with the majority of the duct-work, you might want to default your zone dampers to the Close position.

During the Winter, the attic gets cold and during the off cycle the attic duct-work (and FAU) also gets cold. Warm air in the rooms can migrate (rise) up and into the cold duct-work (via the return grille) cool off and migrate (fall) back down into the rooms (via the supply registers).

By closing the zone damper(s) during idle periods, cold or warm air migration via the open duct-work is eliminated.

NOTE: If you select [DMPR DFLT Close], the BMPlus-3z will automatically change the Purge time to 180seconds! This insures the Indoor fan has sufficient time to purge all of the hot or cold air out of the system and stop running, before the BMPlus-3z closes all of the zone dampers.

Purge times lower than 180seconds are not allowed for Damper Default Close function.

The last item in the BMPlus-3z menu is the software version screen. You are now done programming the BMPlus-3z and can operate the zoned HVAC system as desired.

You can change any of the menu selections at any time. Your changes will take effect immediately and are stored in non-volatile memory.

If you want to default the BMPlus-3z back to factory settings, follow the instructions on page 2.

Step 32

Fahrenheit Scale

Or

Celsius Scale

Select your desired Temperature scale

The BMPlus-3z defaults to the Fahrenheit scale for all temperature related functions. If you prefer to use the Celsius temperature scale, make that change right here.

HVAC Zone System Status Screens

By watching the LCD, you can observe several “Zone System Functions” such as: The percent of Heating or Cooling demand on the HVAC system, the Supply Air temperature, the Outside Air Temperature (*requires part #OAS*) and the system static pressure (*requires part #DAPC*) are all displayed automatically. Other diagnostic information may auto-display such as Air Sensor faults, Time Delay countdowns or an S1/S2 lock-out condition. *A great diagnostic tool is the ability to observe Zone Thermostat Demands (as described below) by manually pressing the Up or Down button. When you are finished looking at Zone Thermostat Demand screens, press the left or right button to resume normal LCD scrolling or leave the buttons alone, and the LCD will resume scrolling on it’s own in 10 minutes.*

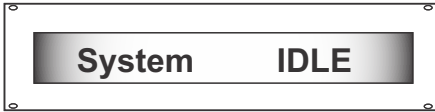

This screen is displayed when there are no active demands from any zone thermostats. Although idle, the Supply Air temperature is displayed at all times.

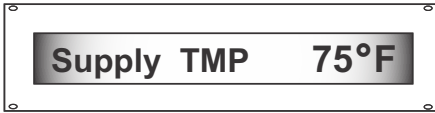

Certain status screens scroll continuously while others are available by pressing the Up or Down button!

[**System COOL ON**] is displayed without pressing any buttons. The [**Z1 Cool Demand**] screen can be observed by pressing the Up or Down button.

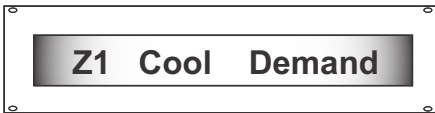

The LCD screen provides true confirmation of the Cooling demand detected from Zone 1. Other zones may be demanding cooling as well, which can be verified by observing their status. Simply press the Up or Down button to observe each zone’s status.

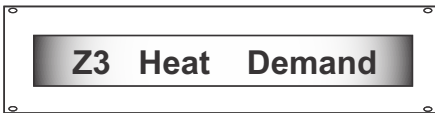
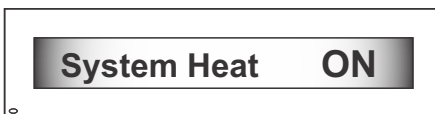

[**System Heat ON**] is also displayed without pressing any buttons. The [**Z3 Heat Demand**] screen can be observed by pressing the Up or Down button.

The LCD screen provides true confirmation of the Heating demand detected from Zone 1. Press the Up or Down button to observe demands coming from other zones.



The BMPlus-3z cannot talk to the XM-3z Expansion Module for Zones 4, 5 & 6. See Troubleshooting page, XM-3z Tech Bulletin #090375A0281.

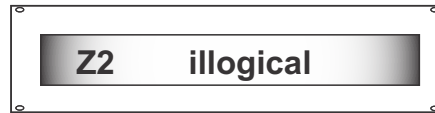

Check the Zone 2 thermostat wiring and programming.



Based on your settings, Zone 2 is not sending a logical cooling demand!

These three screens reflect what you might see when pressing the Up or Down button to observe zone thermostat demand/status.

Zone 5 = Communication Failure with one or both XM-3z.
Zone 2 = Illogical. T’stat 2 wiring/programming is incorrect.
Zone 1 = Logical cooling demand detected from T’stat 1.

The BMPlus-3z is smart and can tell if the zone thermostats are demanding logical cooling and heating demands. **Each zone thermostat must be wired and programmed correctly!**

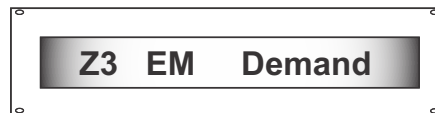

The Zone 1 thermostat is either OFF

Or

Zone 1 is satisfied and does not need Heat

Or

Zone 1 is disconnected

Or

Zone 1 does not exist.

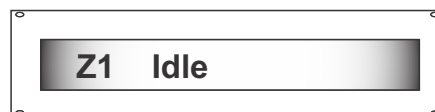
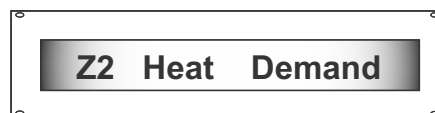

These three screens reflect what you might see when pressing the Up or Down button to observe zone thermostat demand/status.

Zone 3 = Logical Emergency demand detected from T’stat 3.
Zone 2 = Logical Heating demand detected from T’stat 2.
Zone 1 = Idle. No demands detected from T’stat 1.

The BMPlus-3z is smart and can tell if the zone thermostats are demanding logical cooling and heating demands.

Opposing demands are accommodated via the “Opposing Demand Timer” feature.

HVAC Zone System Status Screens

A Supply Air temperature sensor (P# SAS) is included with the BMPlus-3z. *EWC highly recommends that it be installed and utilized, allowing the Installer and the End User to observe the supply air temperature in real time.*

The BMPlus-3z will display several status screens for the benefit of the Installer and End User. Supply & Outside air temperature, Cool & Heat delay count-down, Purge & Change-over delay count-down, including 'fault' status of the S1/S2 safety circuit is also displayed. Some of these status screens scroll by automatically on the LCD while other status screens are observed by pressing the Up or Down buttons.

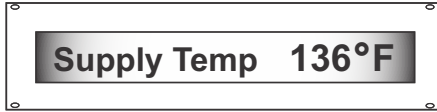

Refer to SAS Submittal # 090377A0072

A Supply Air Sensor (#SAS) is a standard accessory and is included with the BMPlus-3z. When properly installed and wired, the BMPlus-3z will display the real time supply air temperature of the HVAC system during all modes of operation (Heat, Cool, Fan & Idle).

If the supply air sensor is installed and then becomes disconnected, or the sensor fails (shorted/open) the LCD screen will automatically display the warning message shown below.

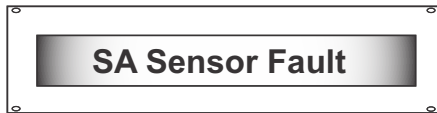

Heating & Cooling demands are still honored, but the BMPlus-3z cannot cycle the HVAC system off-line, if supply air temperature limits are exceeded.

If the supply air sensor is properly connected and the actual supply air temperature exceeds the active Heating or Cooling supply air temperature limit, the BMPlus-3z will cycle the HVAC system off-line for 4 minutes and display a warning message on the LCD.

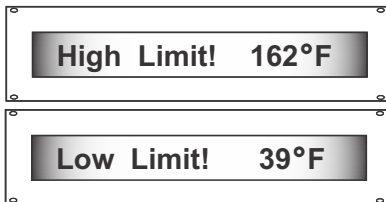

"High Temp Limit Exceeded"

"Low Temp Limit Exceeded"

After 4 minutes has expired and the actual supply air temperature has dropped below the active heating or cooling supply air temperature limit, the BMPlus-3z will resume heating or cooling operations.

NOTE: Even if the supply air temperature moderates quickly (less than 4 minutes) the 4 minute delay must expire, before the BMPlus-3z will resume heating or cooling operations.

LOCATION: The supply air sensor is typically mounted in the supply air plenum on Gas, Oil, Hydronic or Straight Electric heating systems. The sensor can be mounted as close as necessary to the heat exchanger (within 12") because it can with-stand temperatures greater than the HVAC system can produce.

Temperature variations (dead spots) do occur in the supply plenum so selecting a good location is important:

- * Use the genuine Ultra-Zone sensor (# SAS), included in the box. Do Not use other brand sensors or thermistors.
- * Install the sensor in the supply plenum, as close to the mid-air stream as possible, upstream (before) any zone dampers, secondary trunks or branch runs.
- * Do Not install the supply air sensor in the bypass duct or return duct.
- * Avoid splicing the SAS field wiring and creating additional resistance, which will affect temperature accuracy.

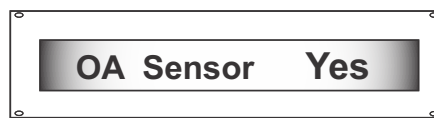
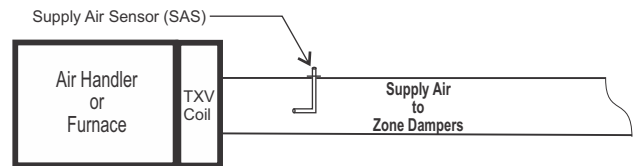

Optional See Page 7, Step 6

If you install an outside air sensor (# OAS) to the BMPlus-3z, the outside air temperature will display on the LCD.

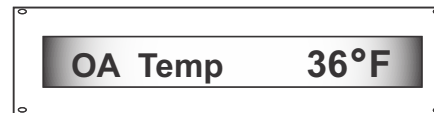

Refer to OAS Submittal # 090377A0073

If the outside air sensor is not connected, becomes disconnected, or the sensor fails (shorted/open) the LCD screen will display the warning message shown below.

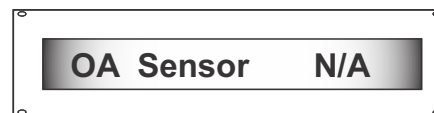

If the BMPlus-3z cannot "detect" the outside air sensor, the BMPlus-3z will lock-out the HP and energize emergency heat only. *Fresh Air functions will also be affected (see page 9) but Cooling functions will operate normally.*

Built-In Time Delay Settings

To avoid redundant or doubling of time delay functions, it may be best to disable each Thermostat's "short cycle" delay.

The BMPlus-3z Time Delays will protect the HVAC system from short cycling.

The BMPlus-3z has built-in Time Delay events to insure safe HVAC system operation!

- * Start-up Delay = 3 minutes, Fixed.
- * Short Cycle Delay = 4 minutes, Fixed.
- * Purge Delay = 60, 90, 120, 150 or 180 seconds.
- * Supply Air Limit Delay = 4 minutes, Fixed.
- * S1 / S2 Safety Delay = 4 minutes, Fixed.
- * Opposing Demand Timer = 20 minutes, Fixed.
- * Changeover Delay = 4 minutes, Fixed.



Momentarily pressing the RIGHT & LEFT buttons clears the built-in timers controlling the Start-up timer, Minimum run timer, Short cycle timer, W2 timer, Supply air sensor timer and the Changeover timer. This enables you to test the installation faster.

Caution should be observed when using these buttons.

Time Delay Definitions

Start-up Delay

Upon initial power-up or after a power failure, the BMPlus-3z will not start or resume operations for 3 minutes.

Short Cycle Delay

After all zones are satisfied, the BMPlus-3z will not re-start the same mode of operation (heating or cooling) for a minimum of 4 minutes. Note: The (default) 90 second Purge Delay runs concurrently (within) the 4 minute Short Cycle delay.

Change-Over Delay

In the event opposing zone thermostat demands occur (heat vs cool or cool vs heat) and the BMPlus-3z terminates the current mode of operation (heating or cooling), a 4 minute delay must expire before the BMPlus-3z will switch to the opposite mode of system operation. **NOTE:** The (default) 90 second Purge Delay does not run concurrently with the Change-Over delay. These two delays run separately.

Purge Delay

At the end of any cooling or heating operation, the BMPlus-3z will hold the "last to call" damper(s) in the open position (all others remain closed) for the time you select. 60, 90, 120, 150 or 180 seconds.

Supply Air Limit Delay

If the BMPlus-3z detects that supply air temperature has exceeded the selected supply air temperature limit, it will cycle the HVAC system off-line. The BMPlus-3z will not resume HVAC operations until the supply air temperature has moderated and 4 minutes has expired. **See page 7 & 16.**

Opposing Demand Timer

A 20 minute delay (starts on every Heat/Cool function) must expire, or the active zone(s) must satisfy, before the BMPlus-3z will honor a zone demand to "changeover" to the opposite mode of system operation.

S1 / S2 Safety Delay

If the S1/S2 circuit opens, the BMPlus-3z will stop all Heating & Cooling operations.
When the S1/S2 circuit closes again, the BMPlus-3z will resume Heating & Cooling operations in 4 minutes. **See page 6.**

LINKS
S1 - S2

S1/S2 Safety Circuit Details

* The S1/S2 jumper link (at bottom left corner) must be cut in order to monitor a safety device. If the S1/S2 link is not cut, the BMPlus-3z cannot detect when the safety device opens the circuit.

* The safety device must have normally closed (fail open) dry contacts!

* **NOTE:** If S1/S2 link is cut by accident, place a jumper wire across S1/S2 terminals.

Figure 2

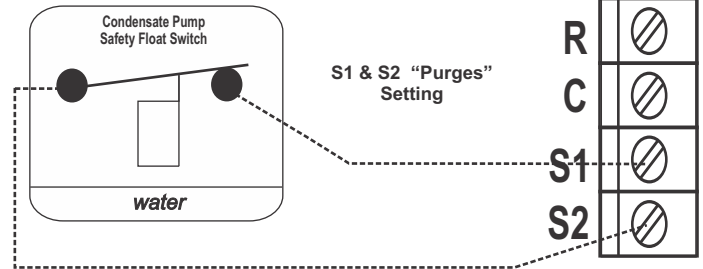

Connect the overflow safety circuit of your condensate pump to the S1/S2 terminals of the BMPlus-3z. So long as the float switch contacts remain closed, the BMPlus-3z will operate the HVAC system. If the contacts open, the BMPlus-3z will open all dampers and run the fan. **NOTE:** The S1/S2 link must be cut!

Figure 3

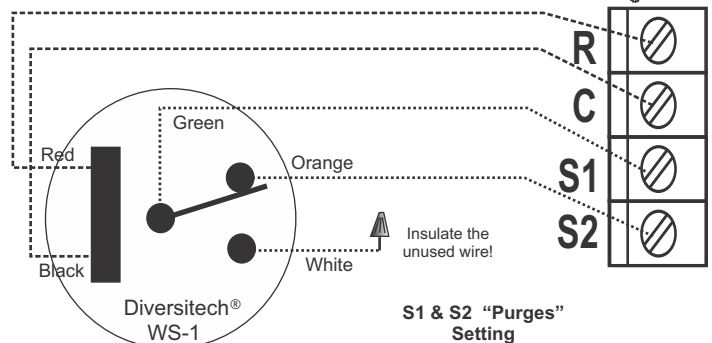

Connect 24vac and S1/S2 terminals to the Emergency "overflow" pan switch as shown. So long as the emergency pan switch contacts remain closed, the BMPlus-3z will operate the HVAC system. If the contacts open, the BMPlus-3z will open all dampers and run the fan. **NOTE:** The S1/S2 link must be cut!

Figure 4

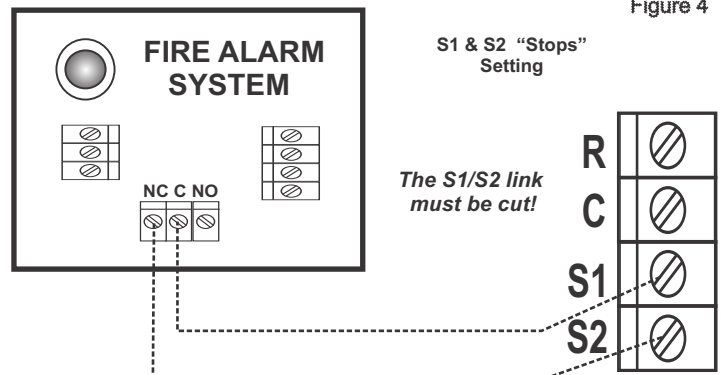

Ask the Fire Alarm Technician to connect your S1/S2 wires to a normally closed (NC) "dry contact" in the Fire Alarm panel. **Note:** The Tech will not let you connect them and if he does allow you, you should decline due to liability.

Confirm with the Technician that the dry contact will "OPEN" when the Fire Alarm system goes into "Alarm Mode". Test the circuit and confirm that the BMPlus-3z shuts down the HVAC system, including the Fan. All directly connected zone dampers should stroke to the "closed" position, to reduce smoke migration. The BMPlus-3z will not resume HVAC operations until the Fire Alarm panel is reset, and the S1/S2 circuit closes. **Warning:** Residential zone dampers are not fire/smoke rated. No claims/guarantees of such are made herein.

3 Zone 1 Heat / 2 Cool Application

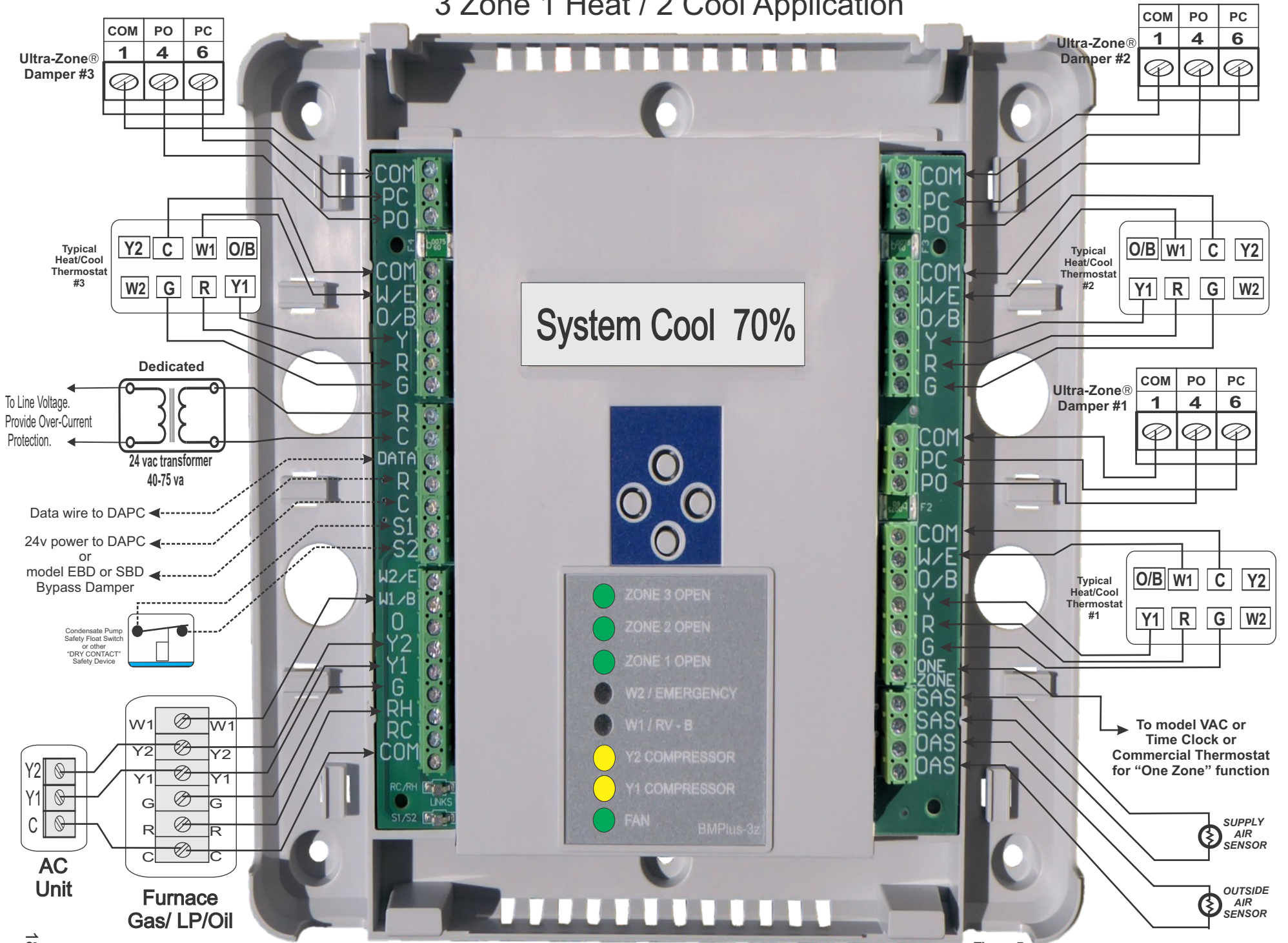

Figure 5

Thermostat Wiring

The BMPlus-3z is easy to understand and wire up. We have provided several examples of Thermostat wiring (and System wiring) on this page and the following pages for your consideration and review.

Since thermostat terminal designation and function varies, depending on the manufacturer, your actual field wiring may differ.

Remember that wire color is important but does not guarantee function! Wiring terminal to terminal (designation to designation) usually works best, regardless of the wire color. *ie, W = W1 and is usually a white wire but it could be a different color. Don't make assumptions!*

POWER WIRING

A dedicated (field supplied) 24vac, UL listed Transformer MUST be installed!
This transformer will power the BMPlus-3z, all Zone Thermostats, all Zone Dampers and Accessories connected to the BMPlus-3z.

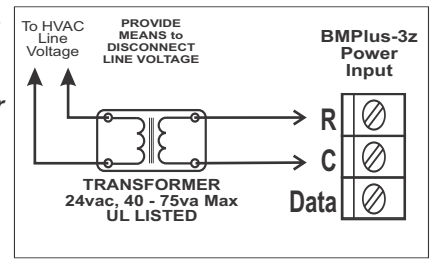

DO NOT rob 24vac power from the HVAC system, to power the BMPlus-3z!

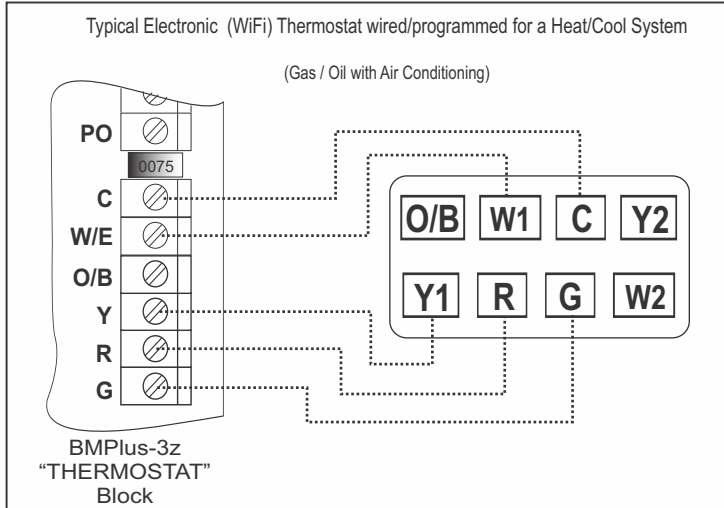

Figure 6 The diagram above reflects a "hard wired" thermostat. That means the thermostat will not function unless the 24v common wire is connected. Most WiFi and Home Automation thermostats require the 24v common wire. See Notes below!

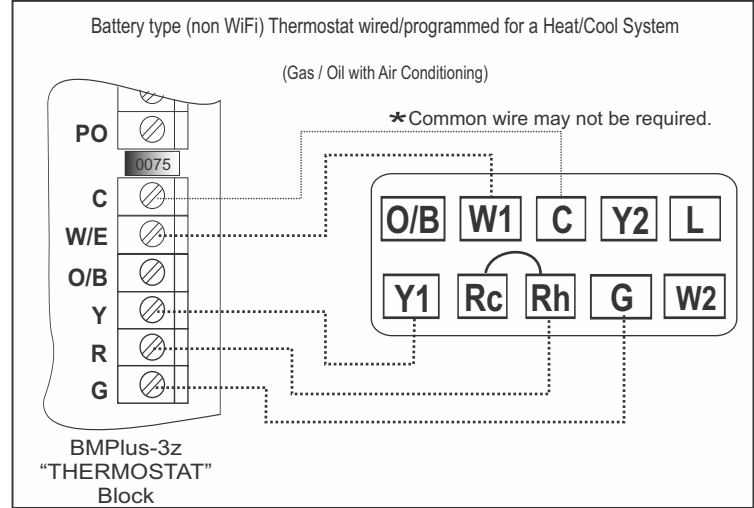

Figure 7 The diagram above reflects a "Battery" or "Power Robbing" thermostat, which means the thermostat only needs four wires. If you have five wires and the thermostat has a C terminal, make use of it and connect the 24v common wire anyway. See Notes below!

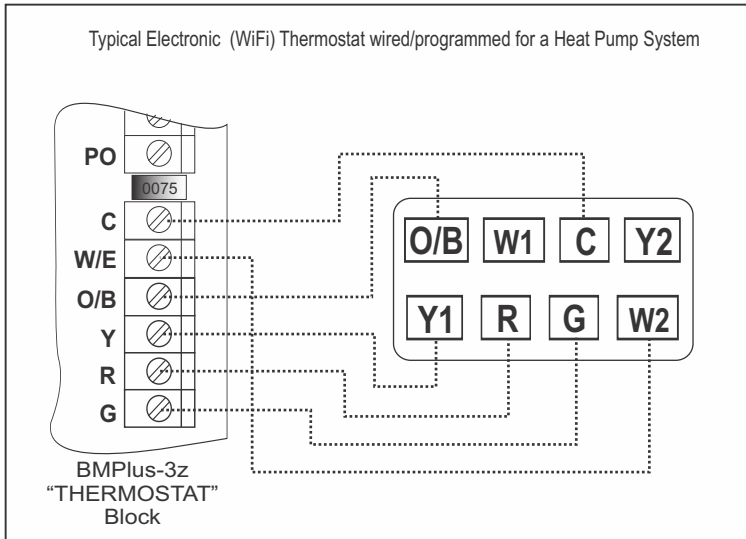

Figure 8 WiFi Heat Pump Thermostat wired/programmed for 2 heat & 1 cool. Your specific HP thermostat wiring may differ. You must program all thermostats and the BMPlus-3z to match the reversing valve logic (O or B) of your Heat Pump!

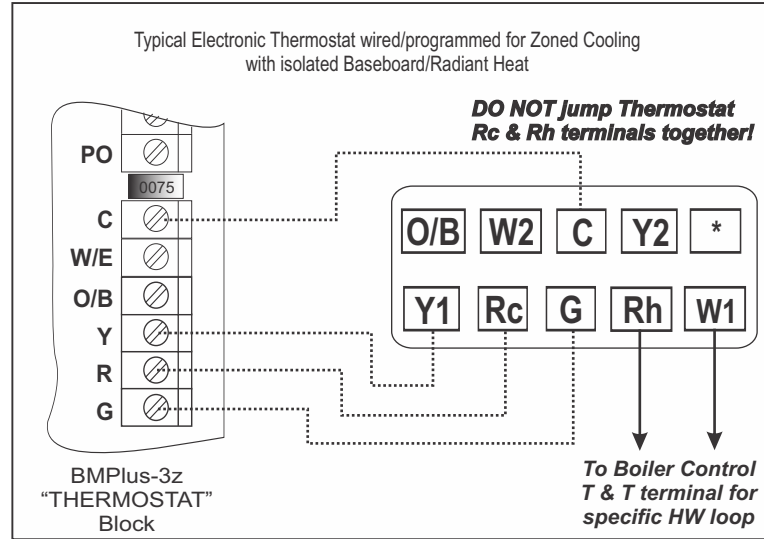

Figure 9 Electronic thermostat configured for Zone Air Cooling with separate Hot Water loop heating. Baseboard or Radiant (in floor) hot water heating loop.

NOTE 1: The BMPlus-3z is compatible with most 24vac (non-communicating) thermostats on the market. Hard Wired thermostats are preferred assuming you have a sufficient number of wires available. See Note 2 below.

NOTE 2: In the event you need a 24v "common" wire and are short by just one wire, you can use the "G" wire for the 24v common and eliminate the "G" circuit. This is a simple/preferred solution versus using an expensive "Power Adapter" (that may or may not work) to achieve the 24v "common" connection to a Hard wired (WiFi) thermostat. See Note 3 below.

NOTE 3: The BMPlus-3z does not need to receive a "G" signal from the thermostat, in order to operate the HVAC system in Cooling or Heating mode. What you give up is the ability to request "Fan Only" from that zone. Cooling, Heating and HP operations will still function properly. Contact EWC Tech Support if you have questions on this solution. See Note 4 below.

NOTE 4: EWC highly recommends that you disable the anti-short cycle compressor delay in all zone thermostats. Some thermostats energize the Auxiliary heat during their anti-short cycle delay which will affect the BMPlus-3z. The BMPlus-3z "built-in" time delays will prevent system short cycling.

System Wiring

WARNING: The BMPlus-3z zone control is designed for use with 24vac only! Do not use other voltages!

Use caution to avoid electric shock and/or equipment damage to this product or the HVAC system. All work should be performed by a qualified technician, to National/Local codes and ordinances. Use 18awg solid copper, color-coded, multi-conductor cable. Plenum rated where applicable. Shielded cable is not required.

Two Stage Furnace w/AC

Typical 2 stage Gas Furnace wiring with single stage Cooling. W2 (High Heat) will be controlled by the BMPlus-3z via the "W2 Heat ON" set-point. See page 9.

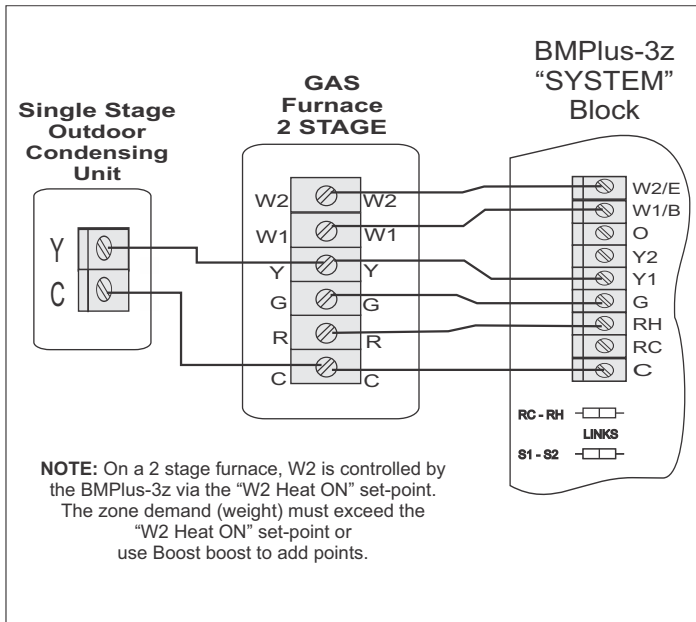

Figure 10

Heat Pump with "O" type Reversing Valve logic

O type heat pumps energize the reversing valve in Cooling mode! Wire the HP reversing valve to the "O" terminal on the system block.

Read the "Important Note" below!

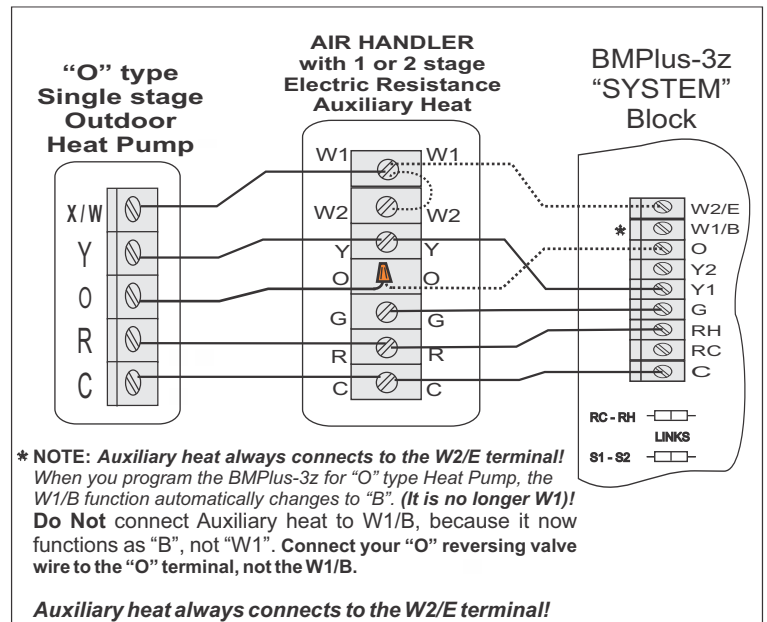

Figure 11

Two Stage Gas/Electric System

Typical system wiring for a 2 stage furnace with 2 stage AC. The BMPlus-3z will control W2 & Y2 via the adjustable "W2 Heat ON" and "Y2 Cool ON" set-points.

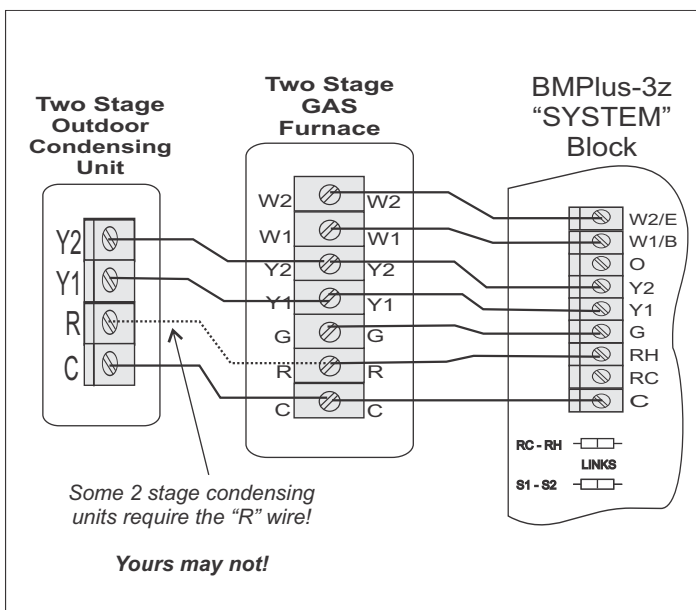

Figure 12

Heat Pump with "B" type Reversing Valve logic

B type heat pumps energize the reversing valve in Heating mode! Wire the HP reversing valve to the "W1/B" terminal on the system block. **Read the "Important Note" below!**

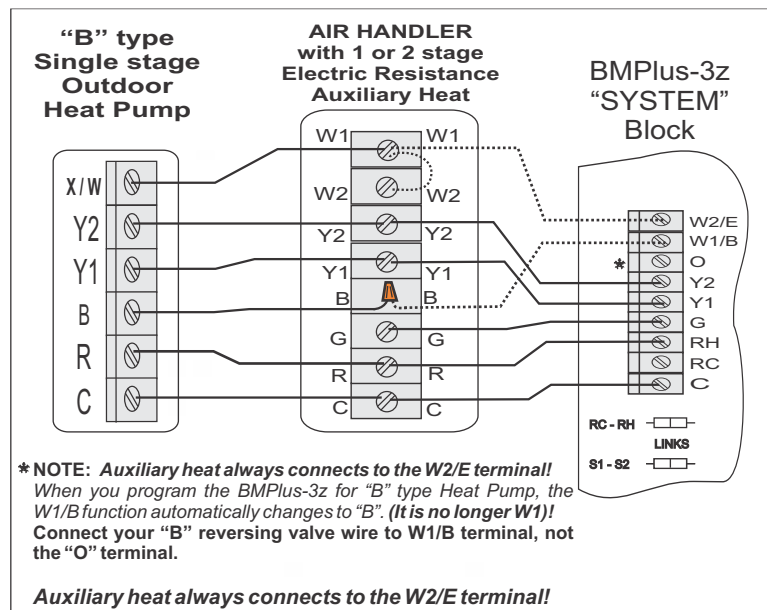

Figure 13

DAMPER WIRING

Note: Each zone (Damper and Thermostat) is protected by a 750mA Auto-Reset Circuit Breaker. This breaker may trip if too many dampers are connected to a single zone and the BMPlus-3z is located in a hot attic. **On a three (3) zone system:**

* You can connect up to 5 Model ND, URD, or SID dampers **per zone (15 total)** when using a 40va transformer. 20 dampers total when using a 50va transformer. Includes a WiFi thermostat (2.5va) on each zone.

* The total number of dampers allowed depends on damper motor current draw, thermostat current draw and the dedicated transformer VA rating. See page 2, Specifications.

PARALLEL versus SERIES wiring

Resist the urge to wire dampers in series, jumping from motor to motor. Wiring multiple motors in parallel (as shown below) reduces the possibility of loose connections and voltage drop.

ZONE DAMPER MOTOR TERMINAL BLOCK DESIGNATION & FUNCTION

- Terminal C - 24vac Common (Neutral)
- Terminal PC - 24vac Power to Close a Damper
- Terminal PO - 24vac Power to Open a Damper

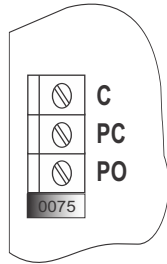

Figure 14

Genuine ND, URD & SID Damper Wiring

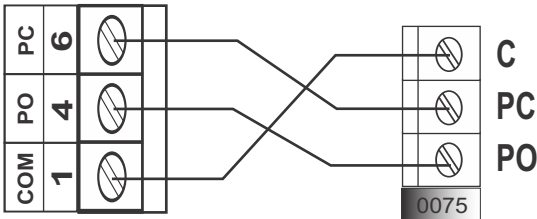

Figure 15

Three ND, URD or SID Dampers on a single zone. No Isolation is Required!

You may connect up to five ND, URD or SID Dampers to a single zone, without an isolation circuit. See figure 17

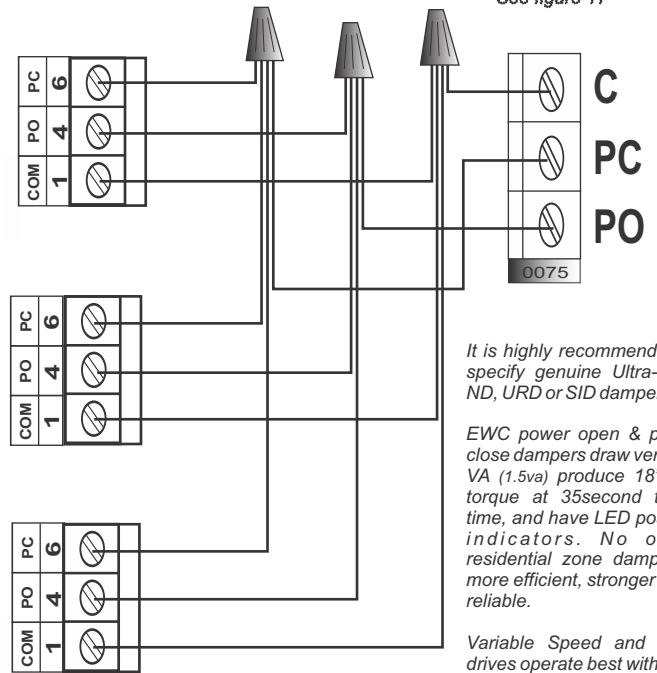

Figure 16

It is highly recommended to specify genuine Ultra-Zone ND, URD or SID dampers.

EWC power open & power close dampers draw very low VA (1.5va) produce 18"lb of torque at 35second travel time, and have LED position indicators. No other residential zone damper is more efficient, stronger or as reliable.

Variable Speed and ECM drives operate best with slow moving Spring or Pneumatic type dampers.

On all damper motors and most older style damper motors (including competitor's dampers) always wire up number to number or by terminal designations.

(C = Com = M1 = 1) - (PO = M4 = 4) - (PC = M6 = 6)

EWC Model dampers:

Rectangular Dampers

ND Submittal Sheet # 090377A0071

ND-15s Submittal Sheet # 090377A0176

Round Dampers

URD Submittal Sheet # 090377A0068

URD-15s Submittal Sheet # 090377A0175

SID Submittal Sheet # 090377A0118

Model BMPlus-3z and DAPC [Power, Data & Zone Damper Wiring with Distributed Air Pressure Controller]

The BMPlus-3z Zone Control can send a digital (Damper Position) signal to the model DAPC, which can modulate your zone dampers to control the static pressure of the HVAC system...In order to achieve this function, the DAPC must be powered from the same 24vac transformer that powers the BMPlus-3z. **NOTE: This diagram is a preferred (Easy Best Practice) 2 or 3 zone configuration!**

When using the "data" terminal, there is no need to connect your zone dampers direct to the BMPlus-3z. The BMPlus-3z will send digital Open/Close damper commands to the DAPC, and the DAPC will Open, Close or Modulate the zone dampers for you!

Install a "dedicated" 24vac transformer to the BMPlus-3z. Then route the 24vac Output & DATA wires from the BMPlus-3z to the DAPC.

Refer to the DAPC
 Technical Bulletin #090375A0270
 for detailed installation instructions!
 Damper Wiring begins at the DAPC,
 Not the Zone Control!

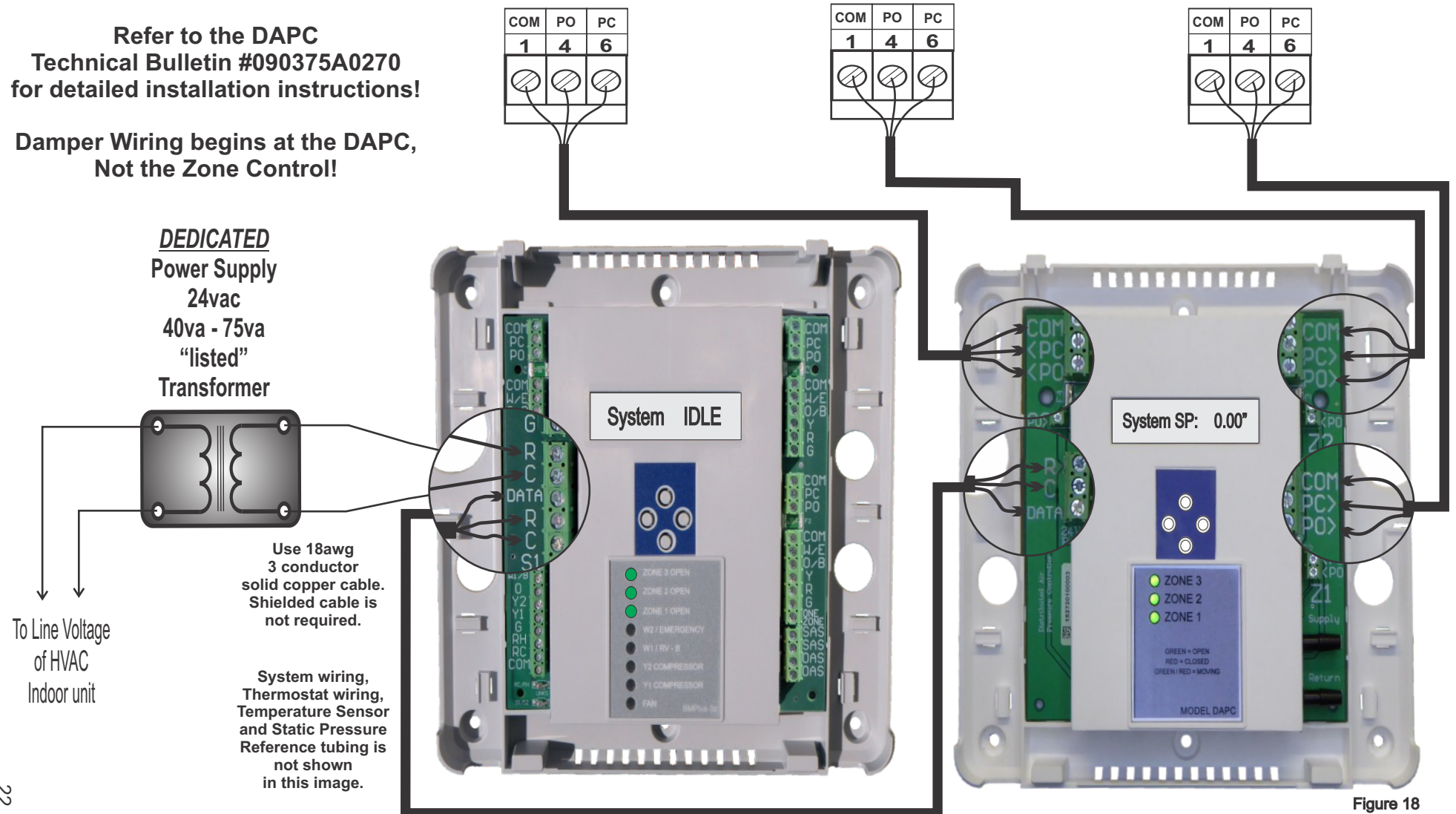

Model BMPlus-3z and Smart Bypass Damper [Power & Zone Damper Wiring with SBD2 Bypass]

You can use the BMPlus-3z 24vac “output” terminals to power Accessories like the Smart Bypass Damper shown below. Note: The 24vac “output” terminals are located just below the 24vac “input” terminals.

You must make sure the BMPlus-3z is powered by a field installed “dedicated” 24vac (40va - 75va) transformer!...So long as you power the BMPlus-3z with a dedicated transformer, you may use the 24vac “output” terminals to power one or more accessory components.

Important Note: *If the accessory component(s) exceeds 15va load rating, you must power the BMPlus-3z with a higher VA rated transformer (50va - 75va).*

Example Below: The SBD2 Bypass motor (1 accessory component) is rated at 4va. *The 40va dedicated transformer is sufficient.*

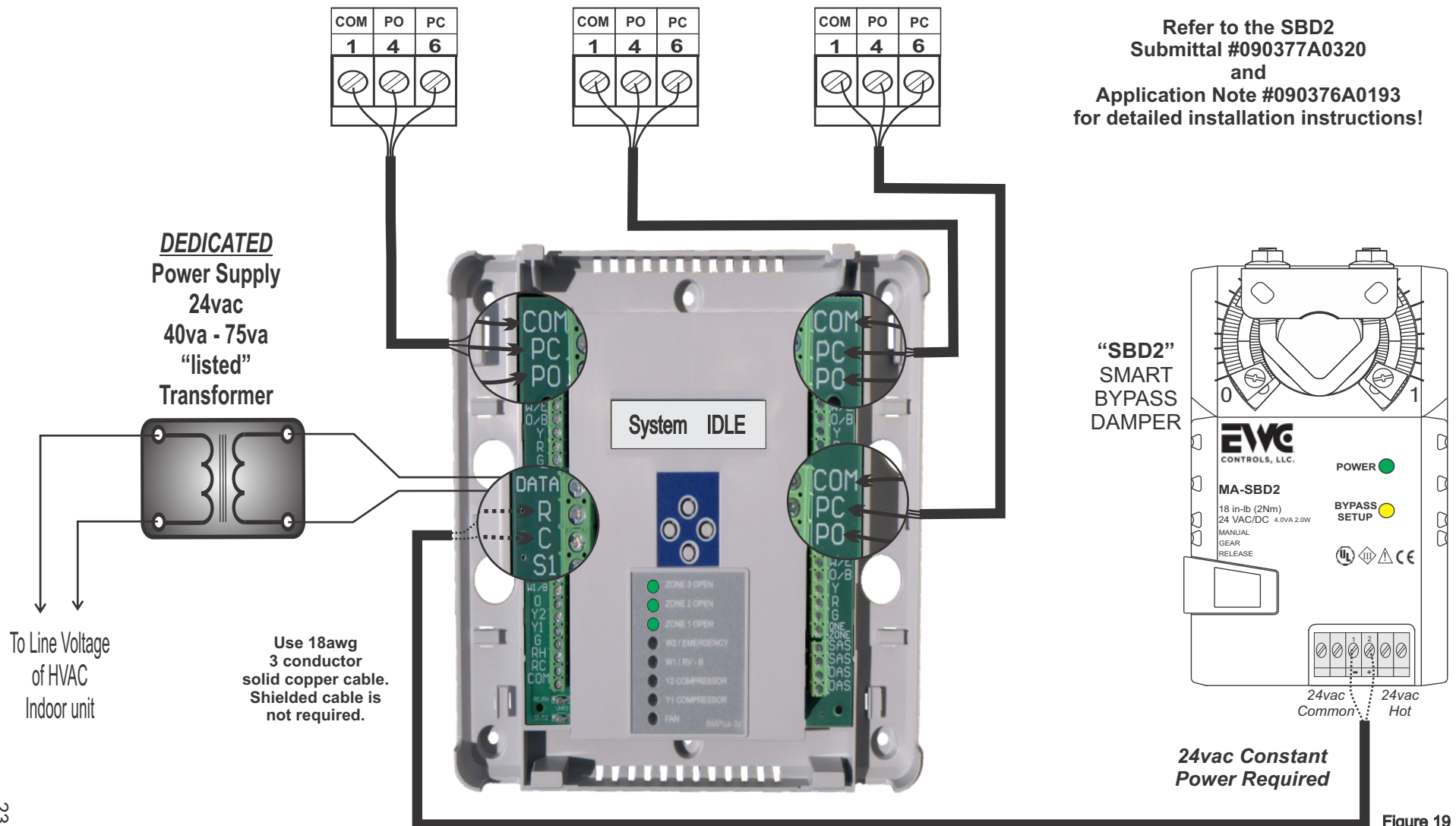

Model BMPlus-6z and DAPC [Power, Data & Zone Damper Wiring]

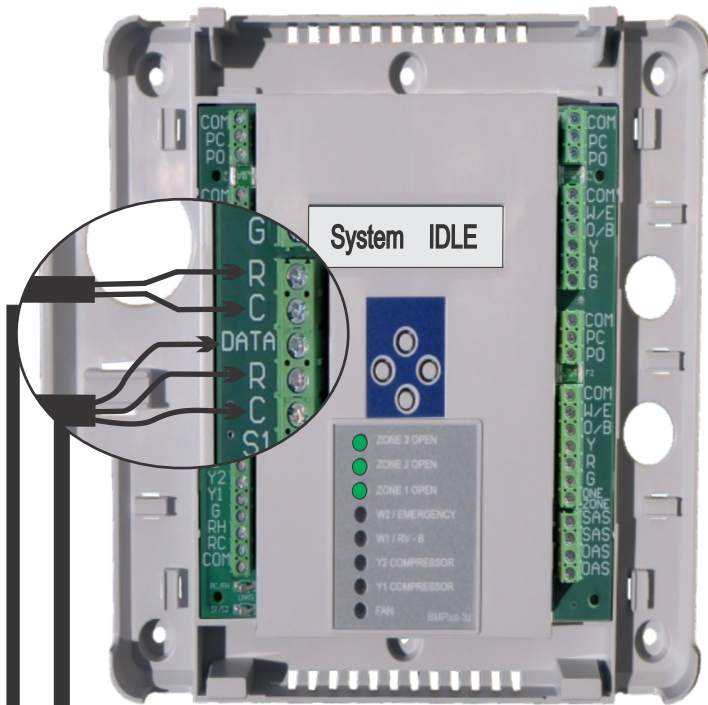

BMPlus-3z with 3 WiFi Tstats = 16va power load

Model BMPlus-3z with one XM-3z Expansion Module, creates a new model BMPlus-6z (six zone) system. See the *XM-3z Tech Bulletin 090375A0281*.

Note that a model DAPC is also included and is controlling Zone 1, 2 & 3 damper motors via Data from the BMPlus-3z.

IMPORTANT: Always connect the largest (high CFM) zones to the BMPlus-3z. Connect the smallest (low CFM) zones to the XM-3z Expansion module(s)!

When it becomes necessary, the DAPC will modulate the largest Zone Dampers 1, 2 & 3, to control the static pressure of the HVAC system & manage the airflow.

Modulating the 3 largest (high CFM) zones (on a 5 or 6 zone system) will provide excellent airflow management and static pressure control, without using a bypass.

Or, you can modulate any 3 zone dampers you like, regardless of which device they are connected to (BMPlus-3z or XM-3z), if you wire the DAPC in legacy mode rather than digital mode. See the *XM-3z Tech Bulletin 090375A0281*.

The calculated power load in this scenario (DAPC, XM-3z, 6 Tstats & 6 PO/PC dampers) equals 50va.

Because the full load calculation equals 50va, you should specify a dedicated 75va transformer!

Use 18awg 3 conductor solid copper cable. Shielded cable is not required.

Connections for 24vac Power and Data!

Route 24v (R & C) from a dedicated transformer to the 24v input on the BMPlus-3z, as shown.

Route 24v (R & C) Output & "Data" from the BMPlus-3z to the 24v Input & "Data" on the XM-3z, as shown.

Route 24v (R & C) Output & "Data" from the XM-3z to the 24v Input & "Data" on the DAPC, as shown.

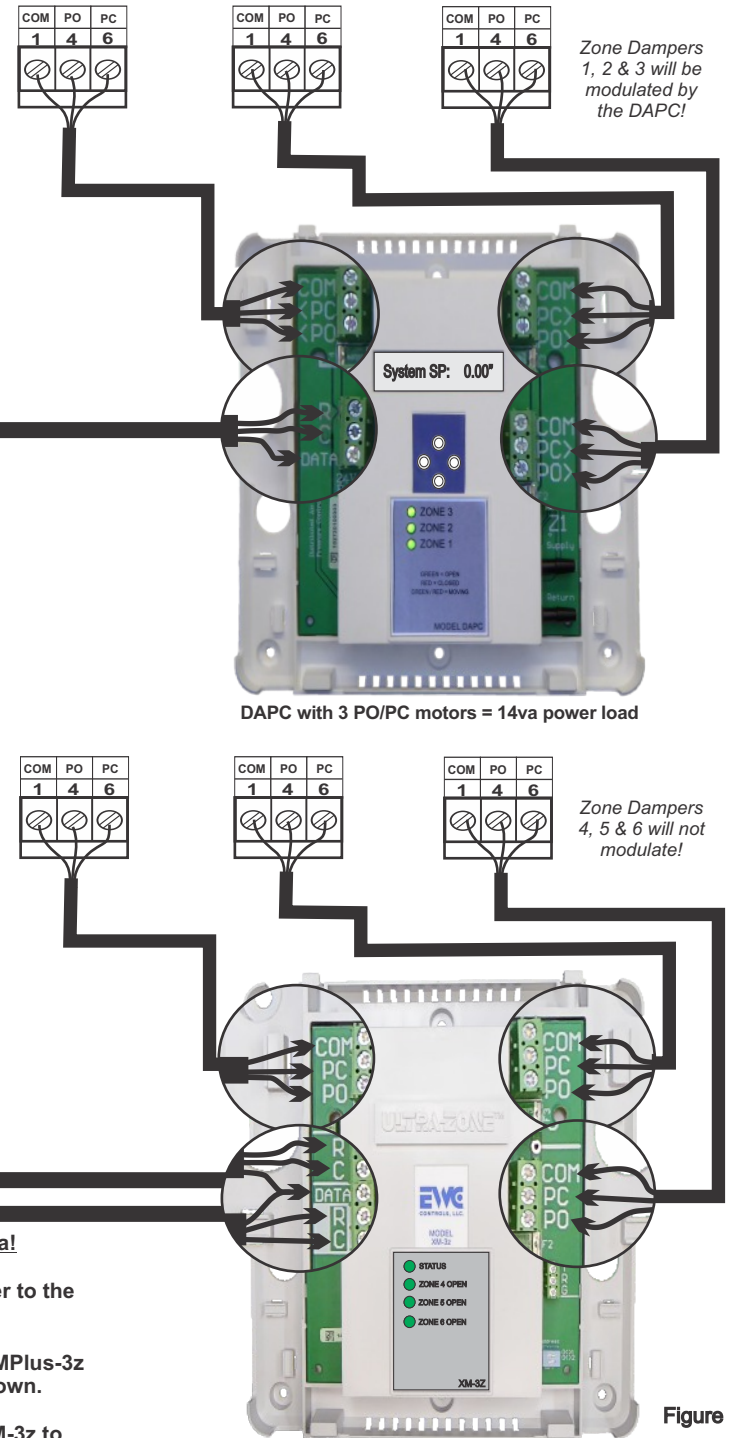

DAPC with 3 PO/PC motors = 14va power load

Zone Dampers 1, 2 & 3 will be modulated by the DAPC!

Zone Dampers 4, 5 & 6 will not modulate!

XM-3z with 3 PO/PC motors & 3 WiFi Tstats = 20va power load

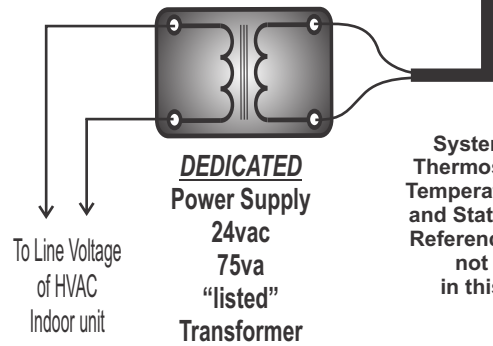

DEDICATED
Power Supply
24vac
75va
"listed"
Transformer

System wiring, Thermostat wiring, Temperature Sensor and Static Pressure Reference tubing is not shown in this image.

To Line Voltage of HVAC Indoor unit

Figure 20

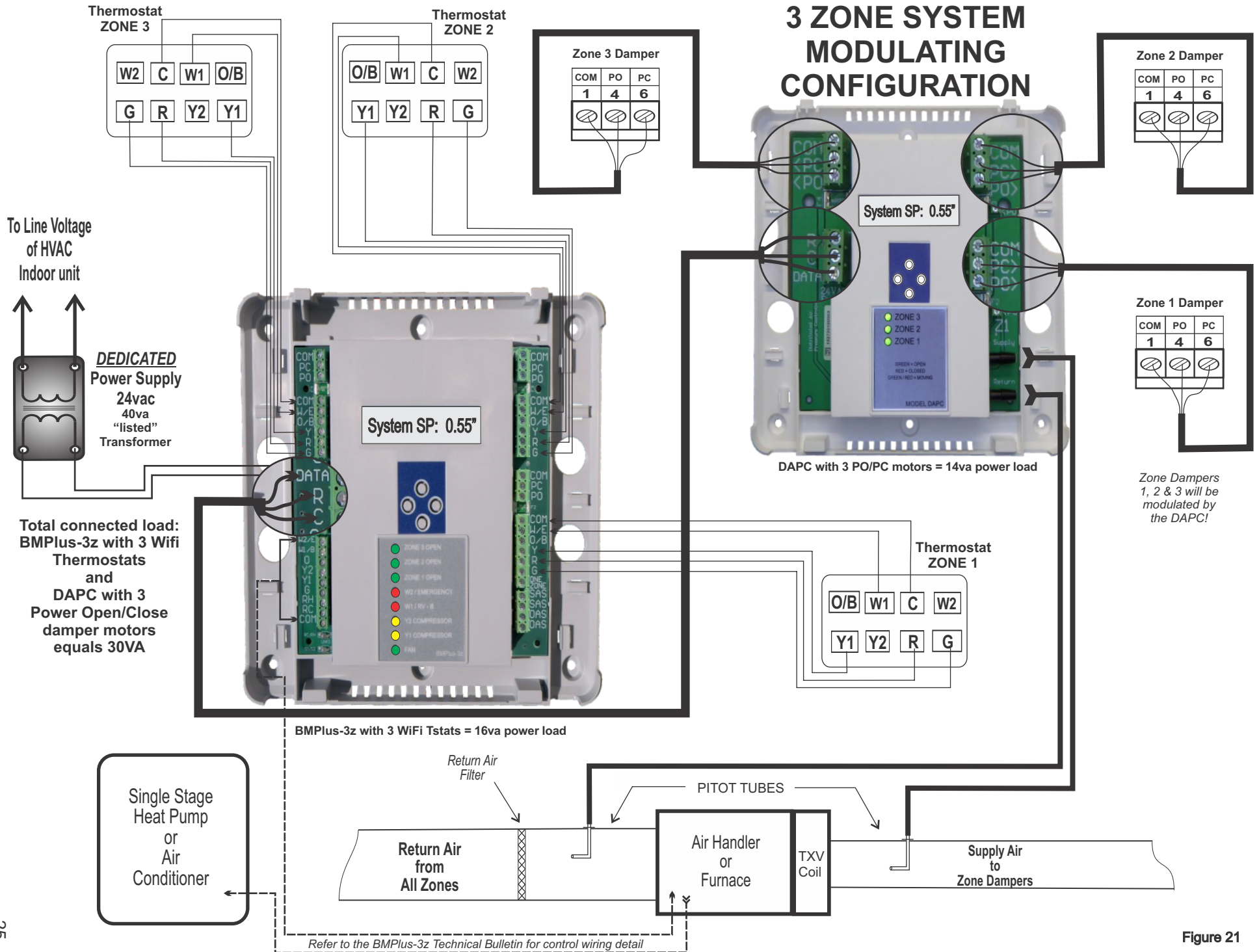

Zone Dampers 1, 2 & 3 will be modulated by the DAPC!

Figure 21

Model BMPlus-9z and two XM-3z's [Power, Data & Zone Damper Wiring]

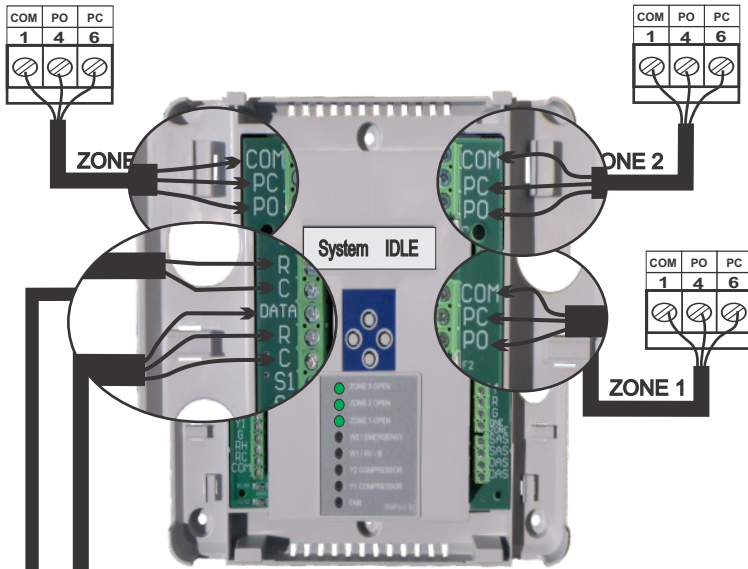

BMPlus-3z with 3 PO/PC motors & 3 WiFi Tstats = 22va

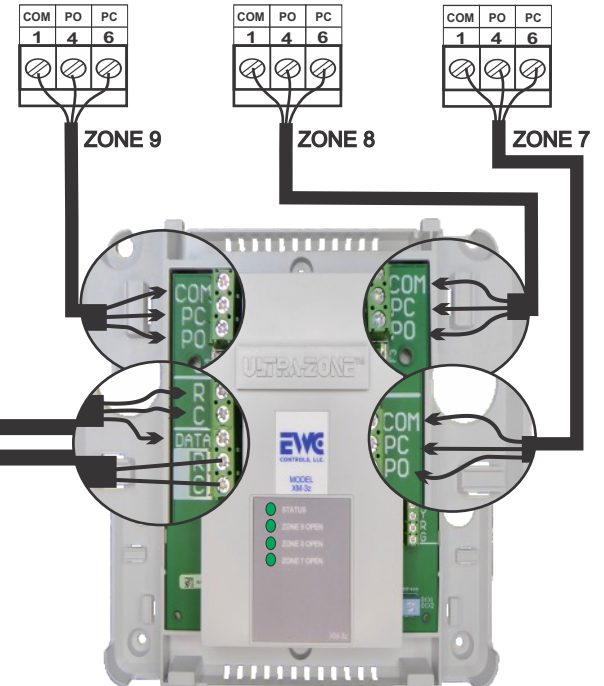
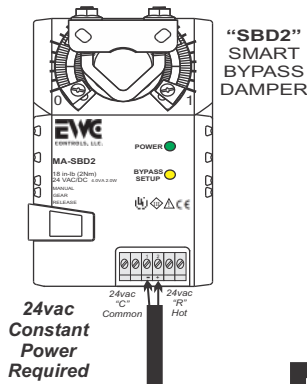

2nd XM-3z with 3 PO/PC motors & 3 WiFi Tstats = 16va

Model BMPlus-3z with two XM-3z Expansion Modules, creates a new model BMPlus-9z system!

Note that a model SBD2 Smart Bypass is also included. When it becomes necessary, the SBD2 will modulate to control the static pressure of the HVAC system and manage excess airflow.

The calculated loads in this scenario (1 - BMPlus-3z, 2 - XM-3z, 9 - Thermostats, 9 - PO/PC dampers and 1 SBD2 Bypass damper) equals 58va.

A dedicated 75va transformer is required to handle this electrical load.

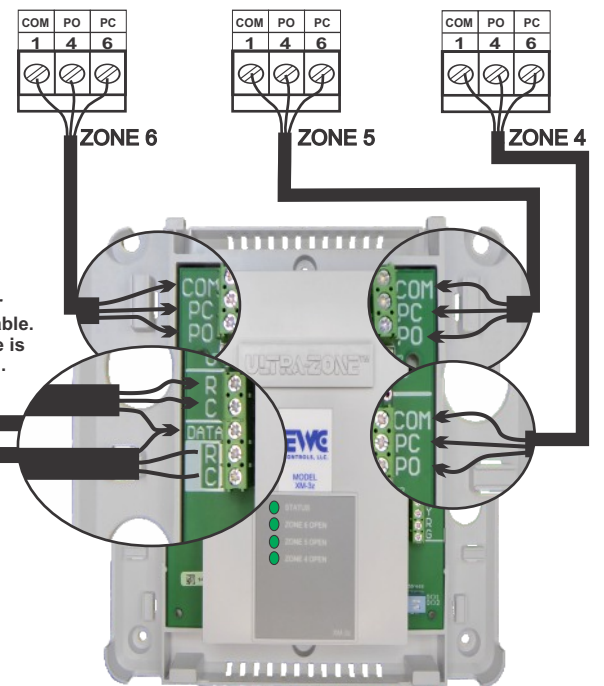

1st XM-3z with 3 PO/PC motors & 3 WiFi Tstats = 16va

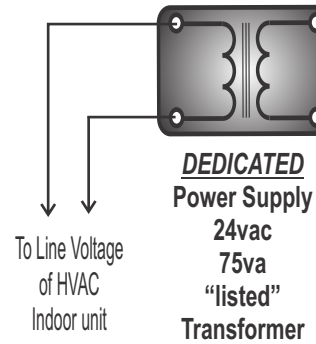

System wiring, Thermostat wiring, Temperature Sensor wiring and SBD2 Static Pressure reference tubing is not shown in this image.

Connections for 24vac Power and Data!

Route 24v (R & C) from a dedicated transformer to the 24v input on the BMPlus-3z, as shown.

Route 24v (R & C) Output & "Data" from the BMPlus-3z to the 24v Input & "Data" on the 1st XM-3z, as shown.

Route 24v (R & C) Output & "Data" from the 1st XM-3z to the 24v Input & "Data" on the 2nd XM-3z, as shown.

Route 24v (R & C) Output from the 2nd XM-3z to the SBD2.

Use 18awg 3 conductor solid copper cable. Shielded cable is not required.

TROUBLESHOOTING

SYMPTOM	SOLUTIONS / CORRECTIVE ACTION
LCD & LED's are not illuminated. BMPlus-3z appears to be dead. HVAC system will not operate.	Check for power at the "24vac Power Input" terminal block. Check transformer line voltage. Check system line voltage. BMPlus-3z <i>must be powered by a dedicated 24vac transformer</i> (40va - 75va). DO NOT rob 24vac power from the HVAC system. Check wet switches that may interrupt 24vac power supply to the BMPlus-3z.
LED's illuminate but HVAC system does not respond. Or HVAC system does not respond & LCD displays "S1/S2 Lock-out"	Check for 24vac power at the "System" block and if zero, check HVAC system line voltage and 24vac power from the Furnace or Air Handler. Check low voltage fuse in Furnace or Air Handler. If 24vac is present at the "System" block, check wet switches or other safety devices that are wired to interrupt the S1/S2 circuit.
LCD & LED's function, but one or more zone thermostat/damper combos will not power up. Other zones work OK.	Check 24vac power (R&C) at the specific thermostat terminal block. If zero, the 750mA breaker protecting that zone has tripped. Check thermostat sub-base and damper circuit for improper wiring/connections. Use an Ohm meter and test thermostat wires for shorts to 24v common and shorts to earth ground. Check damper wiring for shorts as well. 24vac will restore automatically when the short is removed and repaired!
No airflow in a single zone or airflow going to the wrong zone.	Zone Damper wiring (PO/PC) is reversed or Zone 2 damper connected to Zone 1 terminal block, etc. Check Com, PO, PC polarity from each damper terminal block to each damper motor. Trace cabling from each damper terminal block to each damper.
LCD displays "system too HOT/COLD" and the HVAC system is short cycling. OR the HVAC system is working but the LCD displays "Air Sensor Fault"	If a Supply Air Sensor (# SAS) is connected to the BMPlus-3z and the actual supply air temperature exceeds the active Heating/Cooling limit value, a 4 minute delay must expire (<i>and the supply air temperature must moderate</i>) before HVAC functions resume. If the supply air sensor fails (<i>open sensor, shorted sensor or is disconnected</i>) HVAC functions will resume in 4 minutes, but the LCD will display "Sensor Fault" as a warning to check the sensor & sensor field wiring. Replace sensor if necessary.
SYMPTOM	SOLUTIONS / CORRECTIVE ACTION
HVAC system not responding but BMPlus-3z LCD & LED's are working.	If 24vac short has occurred in the "system" wiring, the equipment's 24vac low voltage fuse may be blown. Check equipment low voltage. Find & repair short.
One or more thermostats / damper motors will not power up.	Check 24vac power at the specific thermostat / damper motor terminal blocks. If zero, the related 750mA breaker has tripped. Disconnect wires. Find/repair shorts.
ISOLATING 24vac SHORTS <i>750mA circuit breakers protect each zone and react to a short in the Thermostat or Damper Motor field wiring.</i>	Disconnect wire(s) from the "R & C" terminals on the BMPlus-3z thermostat terminal blocks and the "C/PC/PO" terminals on the damper motor terminal blocks. If the short is no longer present the 750mA breaker will restore power automatically after a few minutes. Test the thermostat & damper field wiring for shorts to 24v common and to earth ground. Repair/replace wires as necessary.

BMPlus-3z LCD & LED DESCRIPTION, COLOR AND FUNCTION

LCD Active / Displays Data = 24vac power is available and processor is functioning.

LCD Active / Display is Dim or Washed out = Check Contrast setting. Adjust as necessary.

ZONE 1, 2 or 3 - Steady GREEN = Open Zones **or** OFF (*Not Green*) = Closed Zone. **Note:** All zones may be Open during idle periods.

W1/RV-B - Solid RED = Gas Heat or "B" reversing valve On-line **or** OFF (*Not Red*) Gas heat or "B" reversing valve Off-line.

W2/E - Solid RED = Auxiliary Heat or Emergency Heat On-line **or** OFF (*Not Red*) Auxiliary Heat/Emergency heat Off-line.

Y2 COMPRESSOR - Solid YELLOW = Compressor On-line **or** OFF (*Not Yellow*) = Compressor Off-line.

Y1 COMPRESSOR - Solid YELLOW = Compressor On-line **or** OFF (*Not Yellow*) = Compressor Off-line.

FAN - Solid GREEN = Fan On-line **or** OFF (*Not Green*) = Fan Off-line.

COMPRESSOR & FAN = Cooling On-line **or** Both LED's OFF (*not Yellow or Green*) = Cooling Off-line.

COMPRESSOR & FAN & W1/B = HP Heating On-Line **or** both LED's OFF (*no Compressor or Fan*) but W1/RV-B still ON = HP Heating Off-line, but holding "B" reversing valve signal waiting for next heat demand.

TECHNICAL SUPPORT

EWC® Controls provides superior Troubleshooting Support for the BMPlus-3z when you are on the job site!

When calling for Technical Support from the job-site, please have a good quality multi-meter, pocket screwdriver, and wire cutters/strippers on hand. Call 1-800-446-3110 Monday - Friday 8am to 5pm EST.

Register your BMPlus-3z 5 year warranty at <https://ewcccontrols.com/warranty/>

Notes ...